



US005974557A

United States Patent [19]

[11] Patent Number: **5,974,557**

Thomas et al.

[45] Date of Patent: ***Oct. 26, 1999**

[54] **METHOD AND SYSTEM FOR PERFORMING THERMAL AND POWER MANAGEMENT FOR A COMPUTER**

5,469,561	11/1995	Takeda .
5,483,102	1/1996	Neal et al. .
5,502,838	3/1996	Kikinis .
5,526,289	6/1996	Dinh et al. .
5,625,826	4/1997	Atkinson .
5,632,037	5/1997	Maher et al. .
5,687,079	11/1997	Bauer et al. .
5,721,938	2/1998	Kurihara et al. .

[76] Inventors: **C. Douglass Thomas**, 1193 Capri Dr., Campbell, Calif. 95008; **Alan E. Thomas**, 424 Atlantic Ave., Ocean City, N.J. 08226

[*] Notice: This patent is subject to a terminal disclaimer.

FOREIGN PATENT DOCUMENTS

[21] Appl. No.: **08/914,299**

0363567	4/1990	European Pat. Off. .
0364222	4/1990	European Pat. Off. .
0368144	5/1990	European Pat. Off. .
0381021	8/1990	European Pat. Off. .
0474963	3/1992	European Pat. Off. .
0496536	7/1992	European Pat. Off. .
0540287	5/1993	European Pat. Off. .
5108193	4/1993	Japan .
5189100	7/1993	Japan .
5-224773	9/1993	Japan .
2235797	3/1991	United Kingdom .
WO91/00523	1/1991	WIPO .

[22] Filed: **Aug. 18, 1997**

Related U.S. Application Data

[63] Continuation of application No. 08/262,754, Jun. 20, 1994, Pat. No. 5,752,011.

[51] Int. Cl.⁶ **G06F 1/32**

[52] U.S. Cl. **713/322**

[58] Field of Search **713/322, 323, 713/501**

OTHER PUBLICATIONS

Advanced Power Management (APM), BIOS Interface Specification, Revision 1.1, Sep. 1993.

Primary Examiner—Thomas M. Heckler

[56] References Cited

U.S. PATENT DOCUMENTS

4,448,543	5/1984	Vail .
4,672,228	6/1987	Swoboda .
5,021,679	6/1991	Fairbanks et al. .
5,036,493	7/1991	Nielsen .
5,121,291	6/1992	Cope et al. .
5,134,703	7/1992	Bumbarger .
5,167,024	11/1992	Smith et al. .
5,189,314	2/1993	Georgiou et al. .
5,201,059	4/1993	Nguyen .
5,218,704	6/1993	Watts, Jr. et al. .
5,230,055	7/1993	Katz et al. .
5,239,652	8/1993	Siebert et al. .
5,241,680	8/1993	Cole et al. .
5,249,741	10/1993	Bistline et al. .
5,287,244	2/1994	Hileman et al. .
5,287,292	2/1994	Kenny et al. .
5,349,823	9/1994	Solomon .
5,396,635	3/1995	Fung .
5,428,790	6/1995	Harper et al. .
5,442,806	8/1995	Chen et al. .
5,469,320	11/1995	Walker et al. .

[57] ABSTRACT

Novel techniques for controlling a processor's clock frequency and/or fan so as to prevent overheating are disclosed. The invention attempts to maximize the processing speed of the processor while preventing overheating or to reduce power consumption. In a preferred embodiment, the invention monitors a processor's activity and its temperature. When there is no activity for the processor, a slowed clock frequency is used, thereby saving power and lowering the thermal heat produced by the processor. On the other hand, when there is activity for the processor, a fast clock frequency is used. However, when prolonged activity (i.e., sustained fast clock frequency) causes the processor's temperature to become dangerously high for proper operation, the clock frequency is reduced and/or a fan is activated so as to prevent overheating. The invention may be implemented as an apparatus or a method.

47 Claims, 8 Drawing Sheets

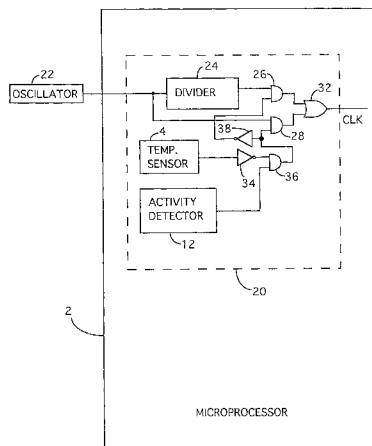

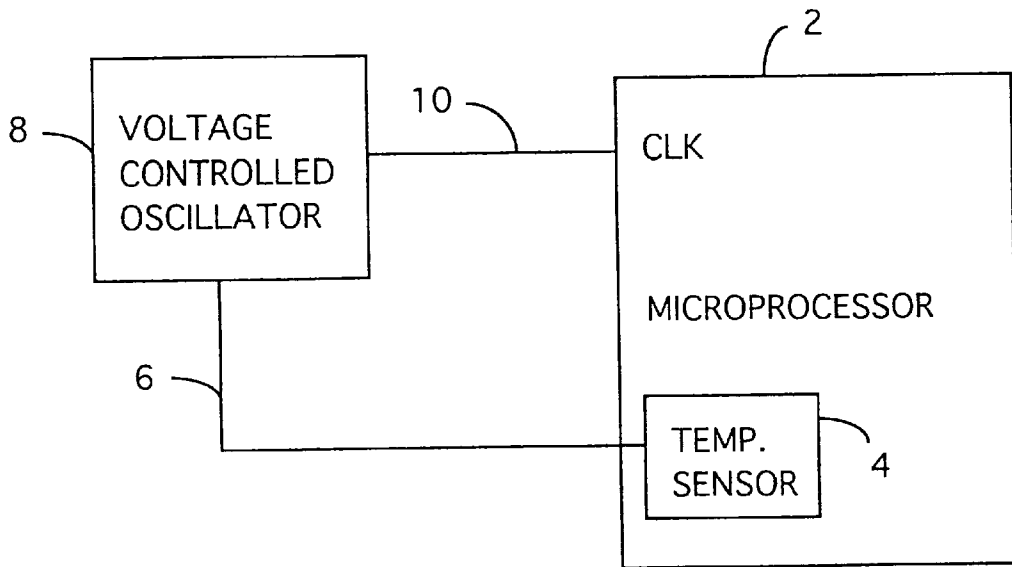

FIG. 1

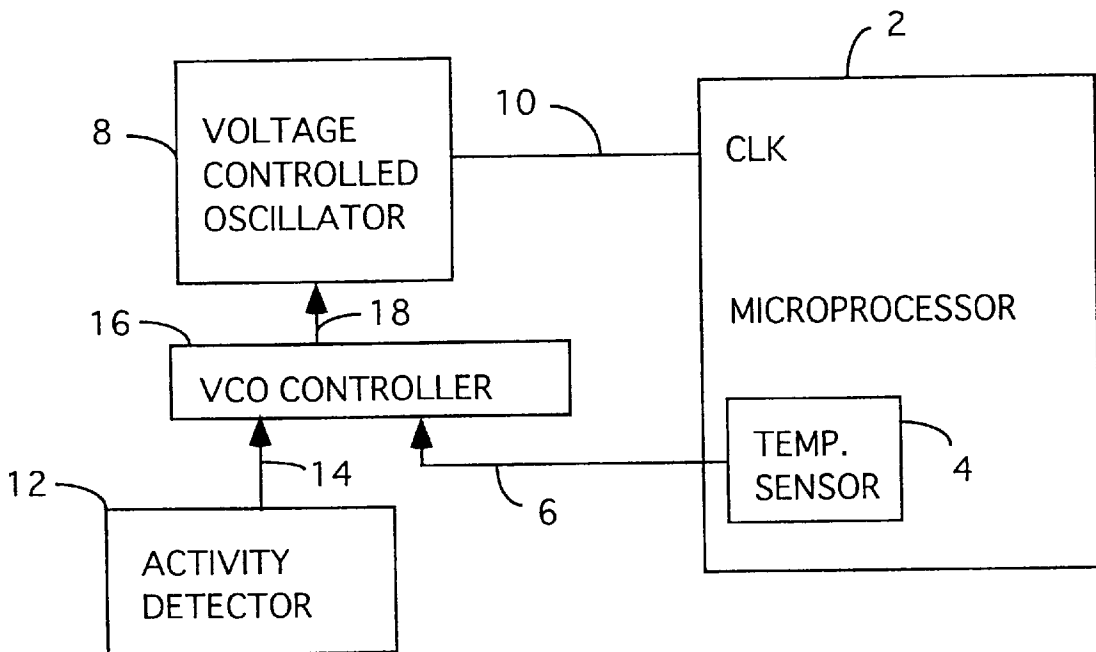

FIG. 3

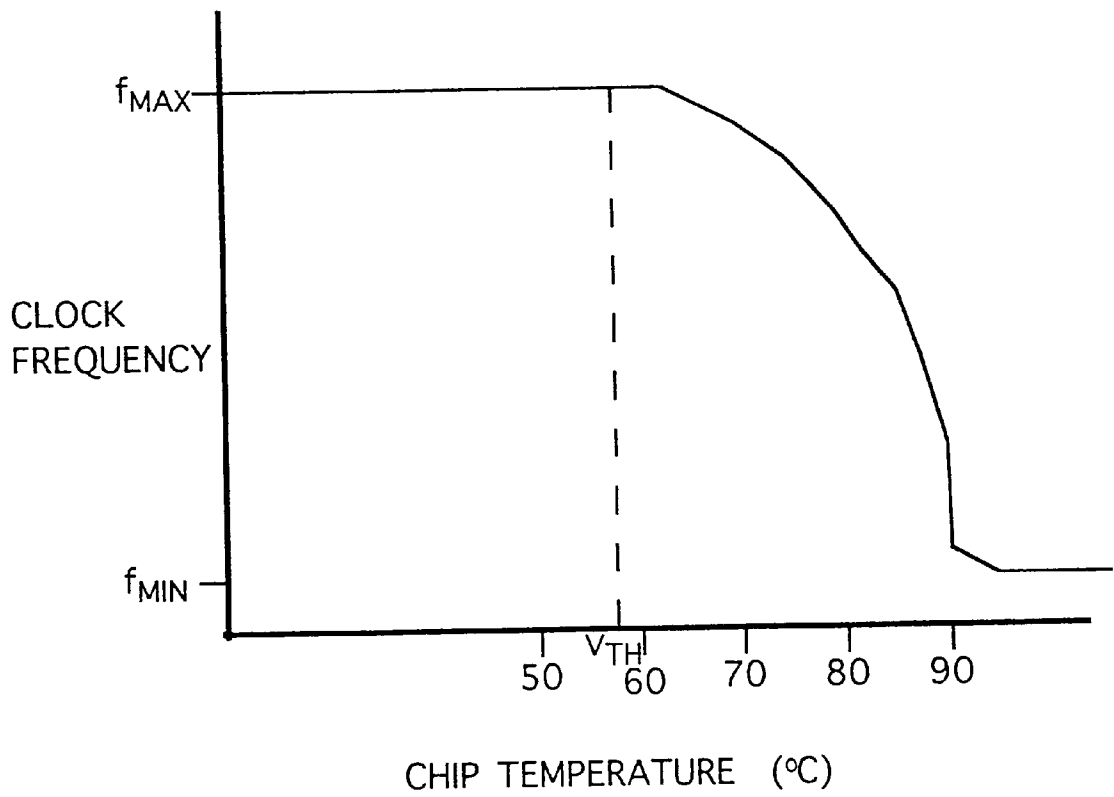

FIG. 2

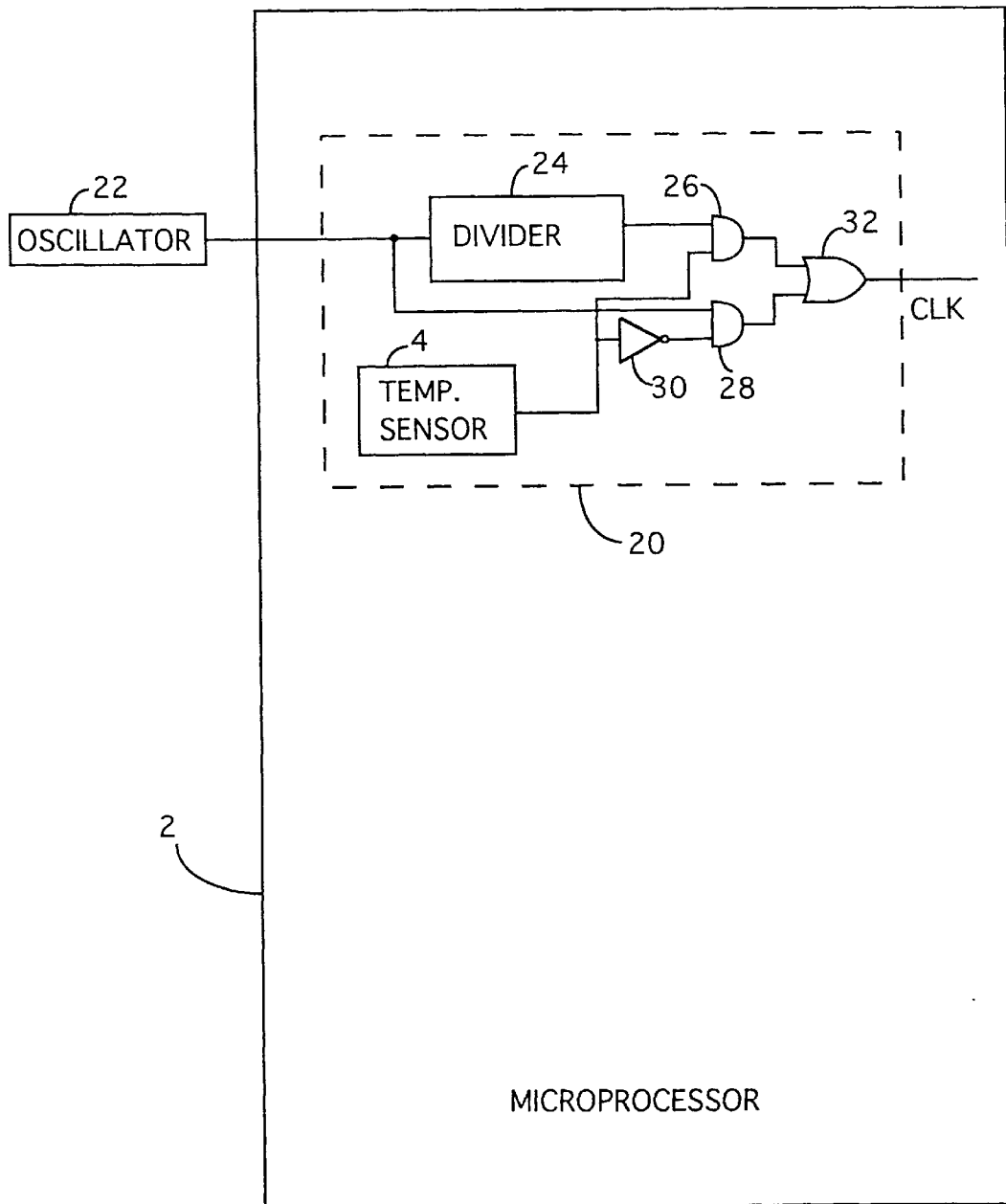

FIG. 4

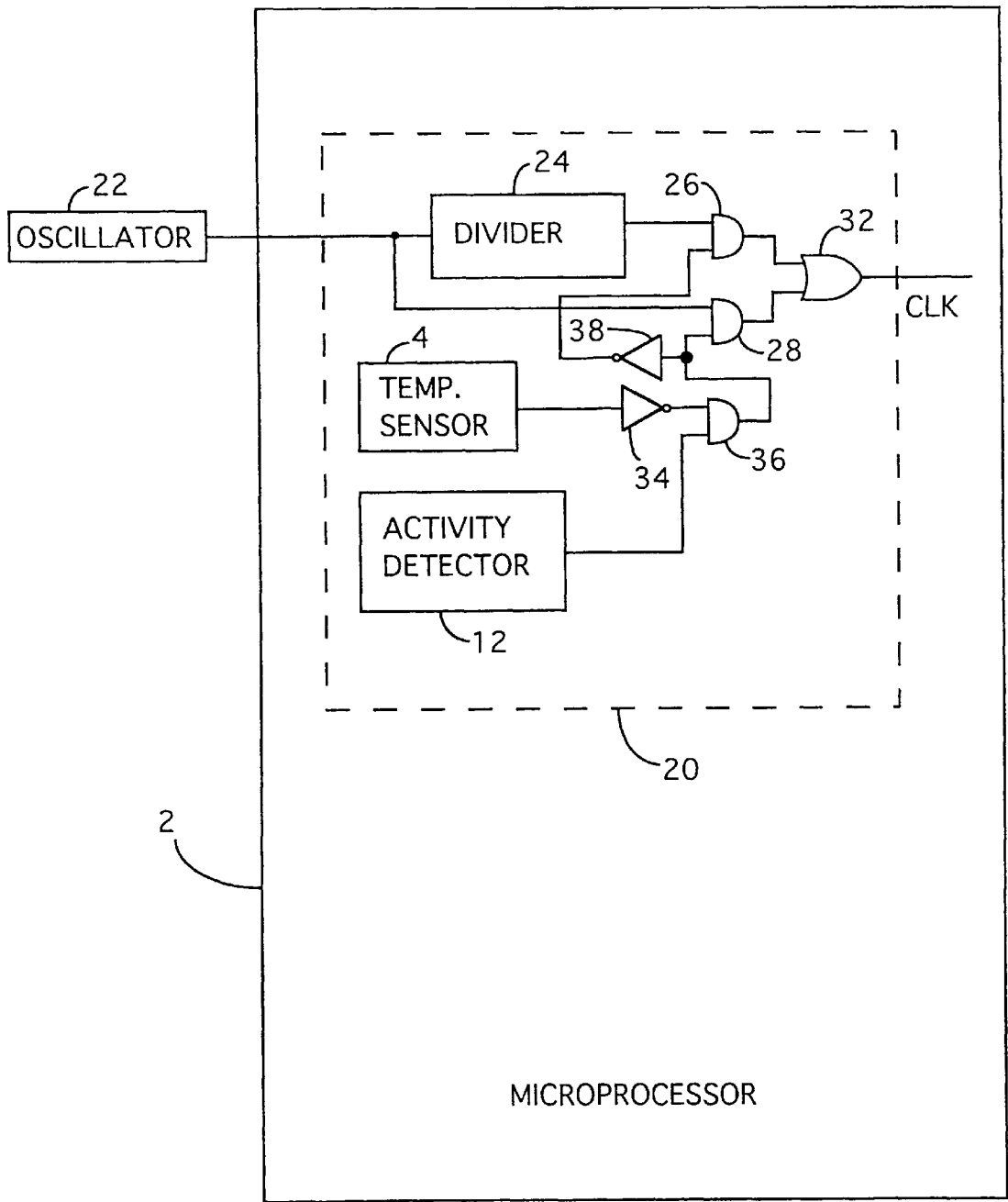

FIG. 5

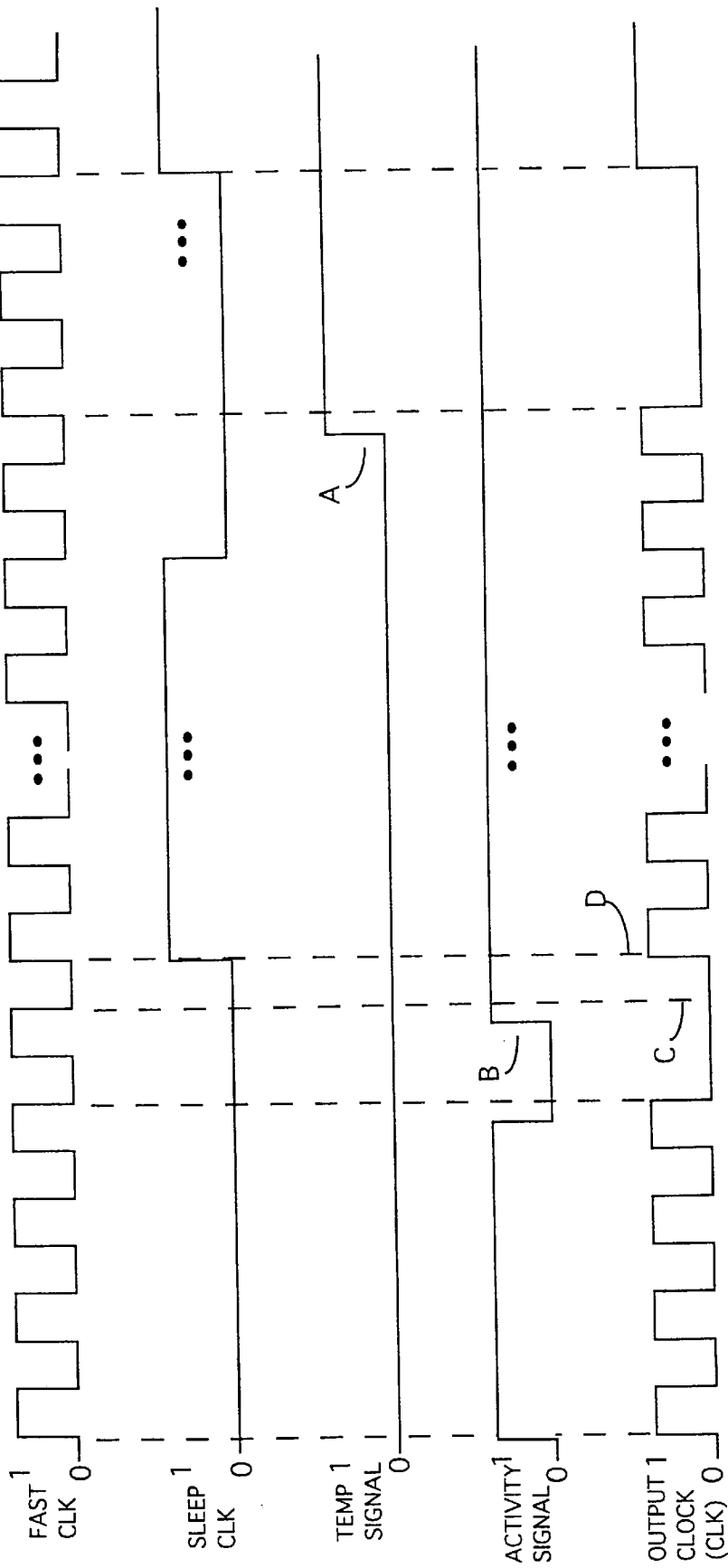

FIG. 6

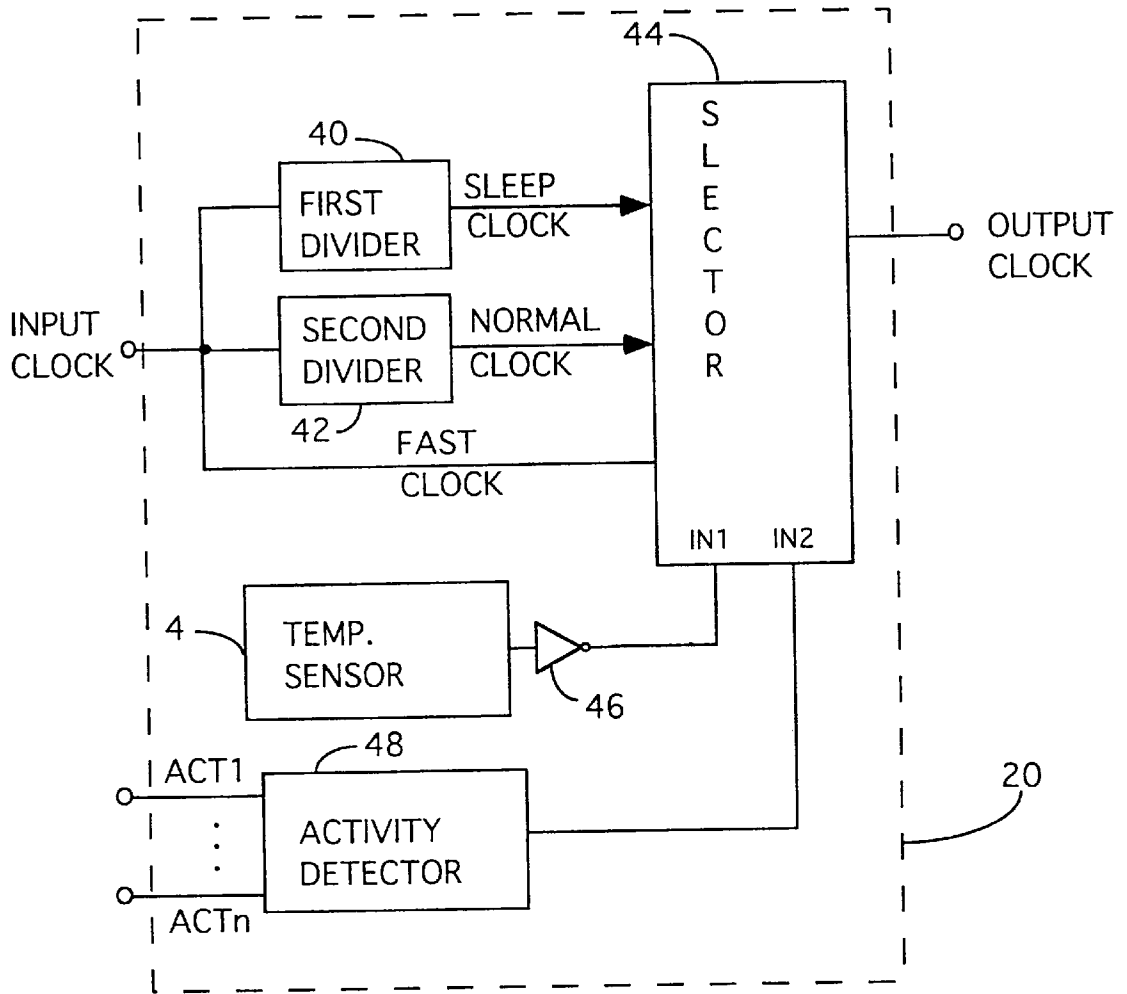

FIG. 7

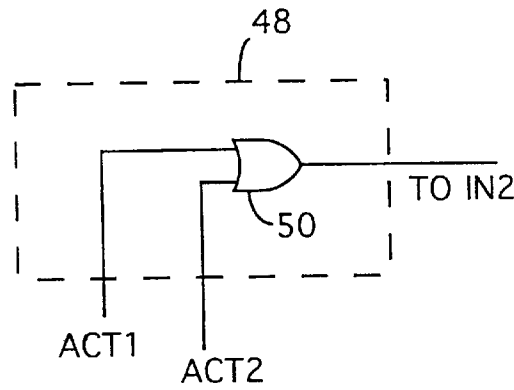

FIG. 8

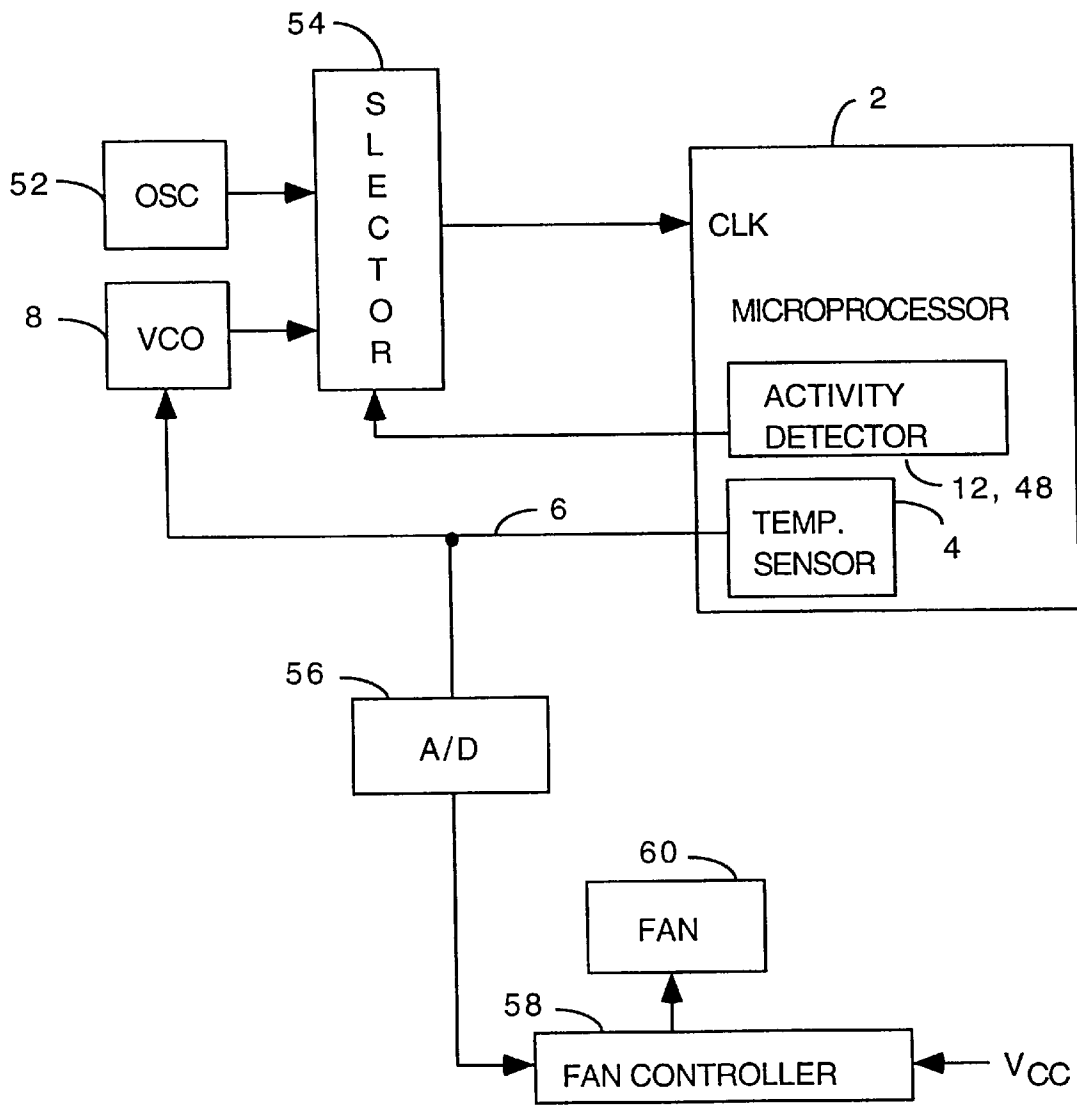

FIG. 9

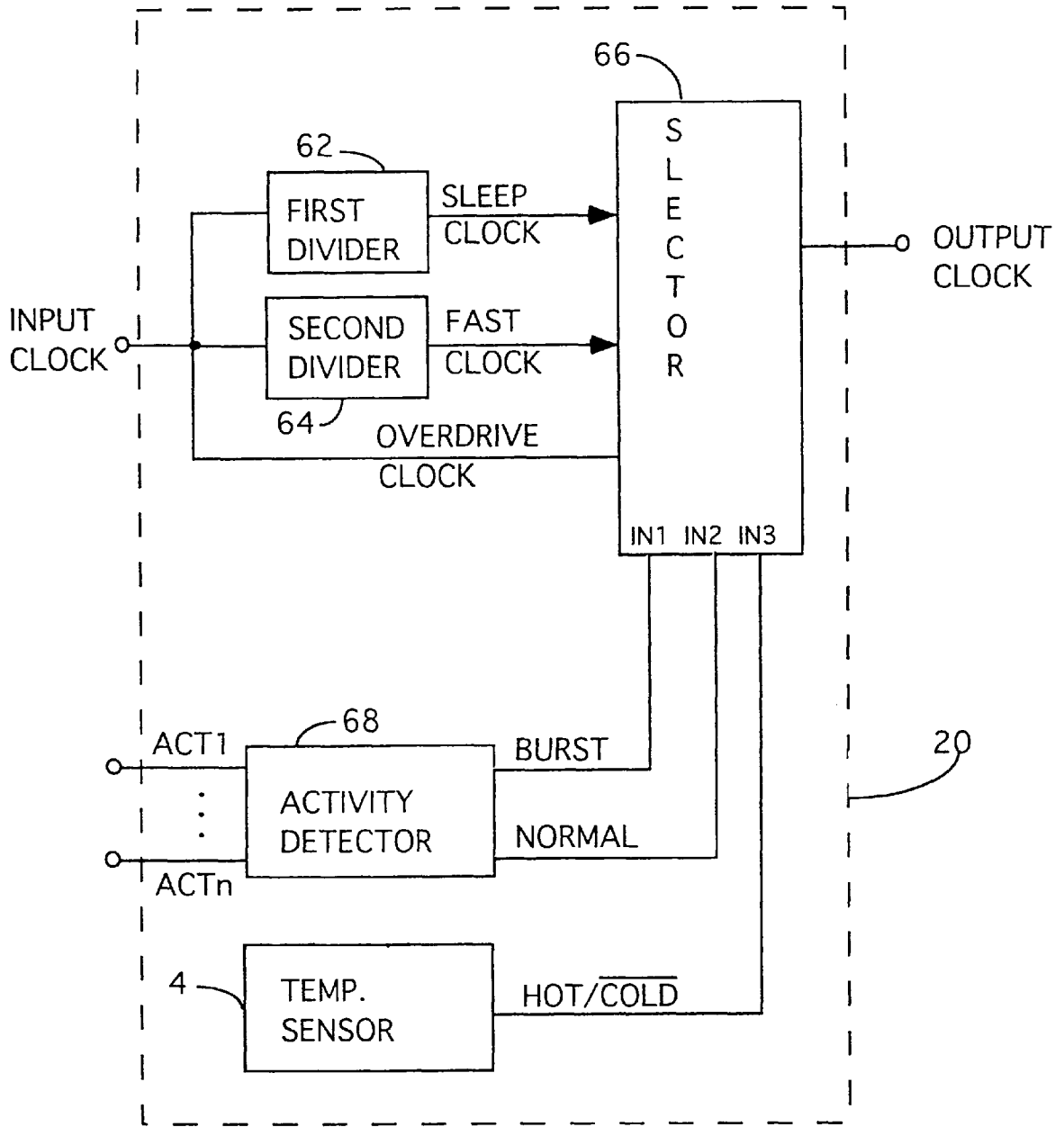

FIG. 10

METHOD AND SYSTEM FOR PERFORMING THERMAL AND POWER MANAGEMENT FOR A COMPUTER

This is a continuation application of prior application Ser. No. 08/262,754 filed on Jun. 20, 1994, now U.S. Pat. No. 5,752,011.

BACKGROUND OF THE INVENTION

1. Field of the Invention

The present invention relates to a computing device and, more particularly, to a method and apparatus for controlling a processor's clock frequency.

2. Description of the Related Art

It is known that if no user activity has occurred for a period of time that a portable computer can be placed in a suspend or sleep mode. It is also known to suspend or slow a computer's processor (e.g., microprocessor, CPU) when the processor is not actively processing. The following patents and patent publications are representative of the current state of the art:

(a) U.S. Pat. No. 5,201,059 discloses a sleep mode which is activated when control given to BIOS or alternatively by incorporating some statistical analysis of the frequency of BIOS calls. In this patent, the sleep mode either stops the clock or slows it to 4 MHz.

(b) U.S. Pat. No. 5,167,024 discloses a power management system for a laptop computer. The power management system operates to disconnect power sources and/or clock signals to various peripheral devices to conserve battery power. The slow mode is entered into when no activity has been detected for a predetermined period of time.

(c) U.S. Pat. No. 5,218,704 discloses a technique for power conservation based on real-time sampling of CPU activity. The activity is sampled during interrupts and when it determines that the CPU may rest, a sleep clock is supplied to the CPU. The detection of an interrupt restores the clock to the fast rate prior to processing the interrupt.

(d) U.S. Pat. No. 5,239,652 discloses a technique for power consumption which disconnects the CPU from the power supply when control logic determines the CPU is not actively processing. Thereafter, the CPU is periodically powered-up to perform housekeeping chores as well as to determine if normal processing should be resumed.

(e) European patent publication EP-0474963 discloses a sleep mode controller which lowers the CPU clock speed when no input/output operation (when keyboard control routine of BIOS executed no input key data in key buffer, or when CPU is idle and no input key data in the key buffer) is performed. The system uses a clock generator circuit which produces the low clock (4 MHz), the high clock (32 MHz) and a slightly slower high clock (16 MHz). A keyboard controller is used to determine which of the high clocks is used, with selection being made by the computer user. The sleep mode controller is disabled if the AC adapter is connected.

(f) U.S. Pat. No. 5,230,055 discloses a portable computer wherein the computer is made inoperable when ambient temperature or humidity become too high. Here, ambient temperature and humidity are periodically monitored.

(g) European patent publication EP-0381021 discloses a power saving system for a personal computer. The system operates to allow or stop power to be supplied to an oscillator based on control data set to a control register via keyboard or software.

(h) U.S. Pat. No. 5,021,679 discloses a power system for a portable computer wherein the supply voltage is varied depending on the current being supplied to the computer by the power system. Further, a variable-frequency clock is provided which varies its frequency based on the supply voltage being produced.

External clocks have been used to provide a computer system with faster clocks. Here, the faster external clock is substituted for the internal clock of the computer system. U.S. Pat. No. 5,134,703 is illustrative of an external clock unit which supplies a faster clock to a computer without requiring any hardware changes within the computer.

The problem with all the prior solutions to energy conservation is that the processors can still overheat. In particular, during prolonged processing or activity by a computer's processor, the processor will not enter its sleep mode (if any) and as a result the processor will become hot and require extensive means to cool the processor to prevent overheating and eventual failure of the processor. Overheating and failure of the processor can also occur when the computer is used in particularly hot environmental temperatures, the computer's cooling fan fails, or when cooling of the processor is otherwise inadequate.

Another problem is that with portable computers, manufacturers have to either use a lower clock frequency (lower than would be used in a comparable desk top computer) for processing or provide a fan for cooling. A lower clock frequency is not satisfactory as users want maximum processing power just as they get with a desk top computer. Requiring a portable computer to use a fan for cooling is also unsatisfactory because it consumes battery energy.

Thus, there is a need for a solution to the above problems which enables a computing device to maximize its processing speed while, at the same time, preventing overheating.

SUMMARY OF THE INVENTION

Broadly speaking, the invention relates to novel techniques for controlling a processor's clock frequency or fan speed so as to prevent overheating. While preventing overheating, the invention attempts to maximize the processing speed of the processor or to conserve power.

Other aspects and advantages of the invention will become apparent from the following detailed description, taken in conjunction with the accompanying drawings, illustrating by way of example the principals of the invention.

BRIEF DESCRIPTION OF THE DRAWINGS

The present invention will be readily understood by the following detailed description in conjunction with the accompanying drawings, wherein like reference numerals designate like structural elements, and in which:

FIG. 1 is a block diagram of a first embodiment of the invention;

FIG. 2 is a graph of an example of the relationship of chip temperature of a microprocessor and frequency of a clock signal;

FIG. 3 is a block diagram of a second embodiment of the invention;

FIG. 4 is a block diagram of a third embodiment of the invention;

FIG. 5 is a block diagram of a fourth embodiment of the invention;

FIG. 6 is a timing diagram illustrating operation of the fourth embodiment;

FIG. 7 is a block diagram of a fifth embodiment of the invention;

FIG. 8 illustrates a schematic diagram of an embodiment of an activity detector;

FIG. 9 is a block diagram of a sixth embodiment of the invention; and

FIG. 10 is a block diagram of a seventh embodiment of the invention.

DETAILED DESCRIPTION OF THE INVENTION

The invention provides novel techniques for controlling a processor's clock frequency so as to prevent overheating. In addition to preventing overheating, the invention attempts to maximize the processing speed of the processor. The invention also operates to conserve the amount of energy consumed by the processor. Preventing the processor from overheating is important because when a processor overheats it no longer operates properly. Conservation of energy, although of general importance for all computing devices, is particularly important for portable computing devices.

The invention monitors a processor's activity and its temperature. When there is no activity for the processor, a slow clock frequency is used, thereby saving power and lowering the thermal heat produced by the processor. On the other hand, when there is activity for the processor, a fast clock frequency is used. However, when prolonged activity (i.e., sustained fast clock frequency) causes the processor's temperature to become dangerously high for proper operation, the clock frequency is reduced so as to maintain processing speed at a reduced speed while preventing overheating.

Embodiments of the invention are discussed below with reference to FIGS. 1-10. However, those skilled in the art will readily appreciate that the detailed description given herein with respect to these figures is for explanatory purposes as the invention extends beyond these limited embodiments.

FIG. 1 is a block diagram of a first embodiment of the invention. In this embodiment, a microprocessor 2 has a temperature sensor 4 which is integral with the microprocessor 2. The temperature sensor 4 is either integrated within the Very Large Scale Integration (VLSI) design of the microprocessor 2 or placed in contact with the housing or package thereof. In either case, the temperature sensor 4 is thermally coupled with the microprocessor 2. Because the temperature sensor 4 is integral or thermally coupled with the microprocessor 2, the temperature sensor 4 is very responsive to the temperature changes of the microprocessor 2. The temperature sensor 4 produces a temperature signal 6. Temperature sensing circuitry is well known and therefore not further described.

The temperature signal 6 is supplied to a voltage-controlled oscillator (VCO) 8. The VCO 8 produces a clock signal 10 which is supplied to a clock input of the microprocessor 2. The VCO 8 operates to produce different frequencies for the clock signal 10 depending on the value of the temperature signal. In this embodiment, the temperature signal 6 is preferably an analog voltage signal and the VCO 8 produces the clock signal 10 based on the value of the analog voltage signal. For example, the temperature signal could be a voltage ranging from zero to five volts. In response to the temperature signal 6, the VCO 8 could produce the clock signal with frequencies ranging from 100 MHz to 1 MHz. The frequency range is a design choice selected in accordance with the specific microprocessor

being utilized. VCO's are well known and therefore are not further described.

FIG. 2 is a graph of an example of the relationship of chip temperature of the microprocessor 2 and clock frequency of the clock signal 10. The clock frequency varies between a maximum frequency (fMAX) and a minimum frequency (fMIN) for given microprocessor. The minimum frequency (fMIN) may be zero if the clock signal 10 is not responsible for refreshing dynamic memory; otherwise, it cannot fall below some minimum frequency. Notice that as the chip temperature increases beyond some threshold temperature (VTH) (e.g., 120 degrees F.), the frequency of the clock signal 10 will gradually decrease. By decreasing the clock frequency in relation to the chip temperature, processing speed can be maximized for a given temperature without risking processor overheating. As the chip temperature become "hot", the clock frequency is reduced so as to reduce the thermal heat generated by the microprocessor 2. The profile of the curve for the clock frequency shown in FIG. 2 is illustrative as other curves may be used. For example, the frequency of the clock signal 10 could be controlled so that the chip temperature is maintained in a more limited temperature range. In any case, the profiles of the curves decrease the clock frequency as the temperature increases.

FIG. 3 is a block diagram of a second embodiment of the invention. In this embodiment, the microprocessor 2, temperature sensor 4, the temperature signal 6, the VCO 8, and the clock signal 10 are similar to those utilized in the first embodiment. However, this embodiment further includes an activity detector 12, an activity signal 14, a VCO controller 16, and a control signal 18.

The activity detector 12 monitors the microprocessor 2 and/or some related peripheral device (e.g., interrupt controller, keyboard buffer, input/output ports, instruction cache, current instruction, program counter) to determine when the microprocessor 2 is actively processing or when processing is needed. In this case, the activity detector 12 notifies the VCO controller 16 that processing is needed with the activity signal 14. On the other hand, when no activity exists, the activity detector 12 notifies the VCO controller 16 that no processing is needed with the activity signal 14. The activity signal is preferably a digital signal having at least one bit. Activity detection is described in more detail in U.S. Pat. No. 5,201,059; U.S. Pat. 5,167,024; U.S. Pat. 5,218,704; U.S. Pat. 5,239,652; and European patent publication EP-0474963, which are hereby incorporated by reference.

The VCO controller 16 receives the activity signal 14 and the temperature signal 6. In response to these signals, the VCO controller 16 produces the control signal 18 which controls the VCO 8. The control signal 18 may be analog or digital depending on the design of the VCO 8. The basic operation of the VCO controller 16 is to cause the VCO 8 to produce the clock signal 10 for the microprocessor 2 in an intelligent manner so as to conserve energy and prevent overheating. Namely, if the activity detector 12 indicates that no processing is needed at a given point in time, then regardless of the temperature detected by the temperature sensor 4, the VCO controller 16 will cause the VCO 8 to produce a sleep (or slow) clock. The sleep clock has a frequency near the minimum frequency (fMIN). On the other hand, if the activity detector 12 indicates that processing is needed at this point in time, then the VCO controller 16 will cause the VCO 8 to produce a fast clock. The fast clock is the temperature-regulated maximum frequency such as discussed in FIGS. 1 and 2.

The second embodiment is particularly advantageous for portable computing devices because it conserves battery life

5

by using a sleep clock when no processing is needed. However, even in the case of prolonged processing, the embodiment prevents overheating.

FIG. 4 is a block diagram of a third embodiment of the invention. In this embodiment, the microprocessor 2 includes a clock regulation unit 20 which controls the frequency of the clock used by the microprocessor 2 based on chip temperature of the microprocessor 2. Preferably, the clock regulation unit 20 is integrated with circuitry of the microprocessor 2. Alternatively, the clock regulation unit 20 can be separate from the circuitry of the microprocessor 2 but nevertheless coupled thereto.

The clock regulation unit 20 receives an input clock from an oscillator 22 and produces an output clock which is used by the microprocessor 2. The clock regulation unit 20 includes a temperature sensor 4, a divider 24, a first AND gate 26, a second AND gate 28, an inverter 30 and an OR gate 32. The temperature sensor 4 is as previously described. The divider 24 divides the input clock (fast clock) from the oscillator 22 to produce a sleep (or slow) clock. For example, if the oscillator 22 is a 100 MHz fixed-frequency oscillator and the divider 24 divides by 100, then the sleep clock would be 1 MHz.

In this embodiment, the temperature sensor 4 produces a digital output. It is assumed that the digital output is normally "0", but when the microprocessor 2 becomes "hot", the digital output becomes "1". The digital output of the temperature sensor 4 together with the logic gates 26-32 operate to select either the fast clock or the sleep clock as the output clock which is used by the microprocessor 2. In particular, when the microprocessor 2 is not "hot", AND gate 26 is inactivated and AND gate 28 is activated by inverter 30. Hence, the output clock is the fast clock via AND gate 28 and OR gate 32. On the other hand, when the microprocessor 2 is "hot", AND gate 26 is activated and AND gate 28 is inactivated. Accordingly, in this case, the output clock is the sleep (or slow) clock via AND gate 26 and OR gate 32. FIG. 5 is a block diagram of a fourth embodiment of the invention. In this embodiment, the microprocessor 2 includes a clock regulation unit 20 which controls the frequency of the clock used by the microprocessor 2 based on chip temperature of the microprocessor 2 and processing activity. The clock regulation unit 20 is preferably integrated with circuitry of the microprocessor 2.

As with the third embodiment, the clock regulation unit 20 for the fourth embodiment receives the input clock from the oscillator 22 and produces the output clock which is used by the microprocessor 2. The clock regulation unit 20 includes the temperature sensor 4, the divider 24, the first AND gate 26, the second AND gate 28, and the OR gate 32 as described above with reference to FIG. 4. The divider 24 divides the input clock (fast clock) from the oscillator 22 to produce a sleep clock. The temperature sensor 4 produces a digital output. Although the digital output from the temperature sensor 4 is normally "0", when the microprocessor 2 becomes "hot", the digital output becomes "1". The activity detector 12 produces an activity signal as described in the second embodiment. Here, the activity signal is a digital signal which is "high" or "1" when activity is present and "low" or "0" when no activity is present.

The digital output of the temperature sensor 4 together with the activity signal from the activity detector 12 and the logic gates 26, 28, 32, 34, 36 and 38 operate to select either the fast clock or the sleep clock. In particular, when the microprocessor 2 is not "hot" and activity is present, the AND gate 36 is activated by the inverter 34 and the activity

6

signal. The output of AND gate 36 then activates AND gate 28 and inverter 38 inactivates AND gate 26. Hence, the output clock is the fast clock via AND gate 28 and OR gate 32. On the other hand, when the microprocessor 2 is "hot", the AND gate 36 is inactivated by the inverter 34 regardless of the activity signal. The output of AND gate 36 inactivates AND gate 28, and inverter 38 activates the AND gate 26. In this case, the output clock is the sleep clock via AND gate 26 and OR gate 32.

FIG. 6 is a timing diagram illustrating operation of the fourth embodiment. The output clock (CLK) is a mixture of the fast clock produced by the oscillator 22 and the sleep clock produced by the divider 24. The temperature signal is the digital output of the temperature sensor 4. The temperature signal is "0" while the chip temperature is not "hot". However, when the chip temperature becomes "hot", the temperature signal becomes "1", as shown at point A. The activity signal is "1" when activity is present for processing by the microprocessor 2; otherwise, the activity signal is "0" to indicate no activity is present for processing. As shown in FIG. 6, the output clock follows the fast clock only when the temperature signal is "0" and the activity signal is "1"; otherwise, the output clock follows the sleep clock. Note that the transitions for the output clock from fast clock to sleep clock and from sleep clock to fast clock are shown as being synchronized with the low or "0" portion of the fast clock. For example, at point B the output clock would produce a partial pulse (from the fast clock) if not synchronized. Hence, it is probably preferred that switching occur only when the fast clock is "low," or when both the fast and sleep clocks are "low" as shown at point C. Note that at point C, the output clock transitions from the sleep clock to the fast clock but because the transition is synchronized with the "low" portion of the fast clock, the first pulse does not occur until point D. Such synchronization can be insured by the addition of known circuitry.

FIG. 7 is a block diagram of a fifth embodiment of the invention. Although only the clock regulation unit 20 is illustrated in FIG. 7, the fifth embodiment interacts with an oscillator 22 and a microprocessor 2 as did the third and fourth embodiments. In this embodiment, the clock regulation unit 20 includes a first divider 40 which divides the input clock (fast clock) to produce a sleep clock, and a second divider 42 which divides the input clock to produce a normal clock. The three clocks (sleep, normal and fast) are then supplied to a selector 44. The selector 44 outputs one of the three clocks as the output clock for the microprocessor 2 IN2. The first select inputs IN1 and IN2. The first select input IN1 is generated by inverting the digital output from the temperature sensor 4 using an inverter 46. The second select input IN2 is generated by an activity detector 48 which functions similarly to the activity detector 12 in previous embodiments.

The activity detector 48 receives a plurality of activity inputs ACT1, . . . , ACTn. For example, the activity inputs notify the activity detector 48 whether or not activity exists. Each of the activity inputs may, for example, indicate an interrupt, keyboard activity, modem line activity, I/O port activity, or processor activity. As an example, FIG. 8 illustrates a schematic diagram of an embodiment of the activity detector 48. The activity detector 48 includes an OR gate 50 which outputs a "1" when either the activity input ACT1 or the activity input ACT2 is "1". If neither the activity signals ACT1 and ACT2 are "1", then the OR gate 50 outputs a "1", thereby indicating the presence of activity.

The following Table I illustrates the selection of one of the three clocks by the selector **44** based on the first select input IN1 and the second select input IN2.

TABLE I

IN1	IN2	CLK Mode
0	0	Sleep
0	1	Fast
1	0	Sleep
1	1	Normal

Note that when no activity is detected by the activity detector **48**, then the sleep clock is output. However, when activity is detected, then the normal clock is output if the chip temperature is "hot" and the fast clock is output if the chip temperature is not "hot". Like previous embodiments, this embodiment prevents overheating and conserves energy. Many alternatives can be made to the third, fourth and fifth embodiments discussed above. For example, additional clocks with different clock frequencies could be provided and selected for different temperature ranges to provide a more gradual decrease in frequency. However, if a microprocessor has sufficient thermal heat dissipation, then even the embodiment with only two different clock frequencies (fast and sleep) may provide reasonable processing speeds even when the microprocessor is getting hot because the switching between the clocks would be quite fast as the response of the temperature sensor **4** is very rapid because it is integrated with the microprocessor. Further, although FIGS. **4**, **5**, and **7** illustrate the temperature sensor **4** as resident within the clock regulation unit **20**, the temperature sensor **20** need only be electrically coupled thereto and closely thermally coupled to the microprocessor **2**.

FIG. **9** is a block diagram of a sixth embodiment of the invention. In this embodiment, the clock (CLK) received by a microprocessor **2** is either a sleep clock produced by an oscillator **52** or a temperature-regulated fast clock produced by a VCO **8** in accordance with a temperature signal **6** (analog) from a temperature sensor **4**. Clock selection is achieved by a selector **54** based on an activity signal **14** provided by an activity detector **12**, **48**. The VCO **8**, the temperature sensor **4** and the activity detector **12**, **48** were discussed above with respect to previous embodiments. If activity is present, the temperature-regulated fast clock is supplied to the microprocessor **2**. On the other hand, if no activity is detected, then the sleep clock is supplied to the microprocessor **2**. The temperature regulation of the fast clock is achieved by the analog temperature signal as discussed above with regard to FIGS. **1** and **2**.

Additionally, FIG. **9** illustrates an additional feature of the invention.

Namely, FIG. **9** includes an analog-to-digital converter **56**, a fan controller **58** and a cooling fan **60**. Many conventional computing systems include a fan for circulating air through a computer's cabinet or add-on fans that provide air-flow on or near a microprocessor. Such add-on fans can be activated in accordance with ambient temperature. In contrast, the invention allows more accurate temperature monitoring of the microprocessor **2** because the temperature sensor **4** is integrated with the microprocessor **2**. In addition, the invention facilitates more sophisticated energy conservation which is particularly important for portable computing devices. The temperature signal **6** is converted to digital form by the A/D converter **56** and then supplied to the fan controller **58**. The fan controller **58** performs a pulse-width modulation operation on a supply voltage (Vcc) so as to

control the speed of the fan **60**. Pulse-width modulation of the supply voltage allows the speed of the fan to be controlled without wasting energy. Thus, this embodiment further includes a temperature-activated, variable-speed fan.

In the case of a desk-top computing device, it is desirable to activate the fan **60** just prior to the temperature where the fast clock would be regulated downward because of high chip temperature. On the other hand, in the case of a portable computing device, it is desirable to attempt to limit the use of the fan **60** as much as possible by allowing the fast clock to be gradually reduced with increasing temperature before utilizing the fan **60**. For example, if the maximum frequency of the fast clock is 100 MHz, the fan **60** could be activated in the desk-top case before the frequency would be regulated (e.g., attempts to maintain 100 MHz). This would eliminate or delay the reduction in the frequency of the fast clock. In the portable case, the fan **60** could be activated after the frequency of the fast clock is already decreased to 25 MHz. The fan **60** would then only be used when necessary to insure reasonable processing power and even then at the lowest effective speed, thereby saving battery energy to the extent possible.

Although not shown but described with reference to FIG. **6**, depending on the particular design, synchronization of the switching of the frequency may be needed to prevent partial pulse in the clock signal. Such synchronization is easily implemented using well-known circuitry. Likewise, if the computing device requires a consistent clock period during certain events (e.g., analog-to-digital conversion), then hysteresis or other circuitry can be added to restrict the ability of the frequency of the clock to be changed during certain times.

Prior embodiments operate to decrease the clock frequency of the clock signals supplied to a microprocessor to prevent overheating and to conserve energy. FIG. **10** is a block diagram of a seventh embodiment of the invention. This embodiment operates to provide a burst processing mode for use under certain conditions. During certain types of processing activity, a clock control unit **20** causes an overdrive clock to be supplied to a microprocessor **2**. Because the overdrive clock is used only in short bursts, the frequency of the overdrive clock can and preferably exceeds the frequency which sustained processing would permit without rapidly overheating.

In this embodiment, the clock control unit **20** includes a first divider **62** which divides the input clock to produce a sleep clock, and a second divider which divides the input clock to produce a fast clock. Because the input clock serves as the overdrive clock, the input clock has a clock frequency that is faster than that necessary for sufficient performance and responsiveness in most cases. The clock control unit **20** also includes a selector **66**, an activity detector **68**, and a temperature sensor **4**. The selector **66** operates to select one of the sleep, fast or overdrive clocks based on select inputs (IN1, IN2, IN3) it receives from the activity detector **68** and the temperature sensor **4**. More particularly, the activity detector **68** receives activity signals ACT1, . . . , ACTn which cause the activity detector **68** to generate a burst activity signal and a normal activity signal. Certain of the activity signals ACT trigger the burst activity signal and other activity signal trigger the normal activity signal. The temperature sensor **4** is integral with the microprocessor **2** and produces a digital temperature signal which indicates whether or not the microprocessor **2** is "hot".

The following Table II illustrates the selection of one of the three clocks by the selector **66** based on the first select input IN1, the second select input IN2, and the third select input.

TABLE I

IN1	IN2	IN3	CLK Mode
0	0	0	Sleep
0	0	1	Sleep
0	1	0	Fast
0	1	1	Sleep
1	0	0	Overdrive
1	0	1	Fast/Sleep
1	1	0	Overdrive
1	1	1	Fast/Sleep

Note that when no activity (either burst or normal) is detected by the activity detector 68, then the sleep clock is output. However, when burst activity is detected, then the overdrive clock is output if the chip temperature is not "hot" and either the fast clock or the sleep clock is output if the chip temperature is "hot". The determination of which of the fast or sleep clocks to output in this situation is a design choice depending on the ability of the computing system to dissipate heat. In fact, it may be preferred to make the selection more sophisticated in this case so that selector can make the decision using addition temperature information such as signals indicating particular temperature ranges or rate at which temperature is rising. When only normal activity is detected, then the fast clock is output if the chip temperature is not "hot" and the sleep clock is output if the chip temperature is "hot". As a modification, the second divider 64 could be replaced with a VCO thereby using a temperature-regulated fast clock.

Like previous embodiments, this embodiment prevents overheating and conserves energy. The advantage of this embodiment is that processing will appear more uniform or regular to a user.

There are certain times during normal execution of a program, the computer is caused to execute operations which are beyond or unrequested by the program being executed. Such unrequested operations include interrupt processing, and data transfer to cache memory following a cache miss. Using the overdrive clock in these types of situations is advantageous because such will substantially lessen any delay induced by these unrequested operations. A computer user then perceives that the computer's responsiveness is more regular and uniform. For example, when a cache miss occurs an instruction currently being in process is not allowed to complete until the appropriate data block is loaded into the cache. The loading of the cache follow a cache miss causes the microprocessor to execute many operations for memory management that were not requested by the computer program or the user, thereby delaying the execution of the instruction. However, because the invention performs such unrequested operations at higher speeds (overdrive clock), the impact of having to perform the extra unrequested operations is substantially lessened and hopefully invisible.

In fact, a particular computer instruction could be used to indirectly select the desired clock frequency for the instruction. This could be useful for instructions that require more intensive processing than do normal instructions. An example of intensive processing is complex floating point computations. Here, the microprocessor would indicate to the activity detector that the overdrive clock is to be used if the chip temperature is not too "hot".

Yet another embodiment would be to alter processing frequency for extremely cold situations. Namely, if the temperature sensor indicates that the chip temperature (could also use ambient temperature) is less than a prede-

termined minimum temperature, then the clock frequency could be set regardless of activity to its maximum value to thereby cause the generation of as much heat as possible so that the computing device could operate correctly even in extremely cold conditions. Any cooling fan of the computing device would also be shut-off using a fan controller such as shown in FIG. 9.

The many features and advantages of the present invention are apparent from the written description and thus it is intended by the appended claims to cover all such features and advantages of the invention. Further, since numerous modifications and changes will readily occur to those skilled in the art, it is not desired to limit the invention to the exact construction and operation as illustrated and described. Hence, all suitable modifications and equivalents may be resorted to as falling within the scope of the invention.

What is claimed is:

1. A computer, comprising:

a processor, said processor processes instructions in accordance with a clock signal;

an activity detector operatively connected to said processor, said activity detector monitors activity of said processor;

a fan; and

a fan controller, said fan controller controls the speed of said fan in accordance with the activity of said processor.

2. A computer as recited in claim 1, wherein power consumption by said fan is substantially reduced by controlling the speed of said fan in accordance with the activity of said processor.

3. A computer as recited in claim 1,

wherein said activity detector determines whether said processor is in a sleep state,

wherein said fan controller causes the speed of said fan to be stopped when said activity detector determines that said processor is in the sleep state, and

wherein said fan controller uses pulse width modulation to control the speed of said fan.

4. A computer as recited in claim 1,

wherein said computer further comprises:

a temperature sensor, said temperature sensor produces a temperature signal based on the temperature of said processor, and

wherein said fan controller controls the speed of said fan in accordance with the activity of said processor and the temperature of said processor.

5. A computer as recited in claim 1,

wherein said computer further comprises a clock module, said clock module produces the clock signal having two or more different frequencies,

wherein said processor processes instructions in accordance with the clock signal supplied from said clock module, and

wherein the frequency of the clock signal is influenced by activity of said fan which serves as an indicator of the temperature of said processor.

6. A computer as recited in claim 1,

wherein said computer further comprises:

a temperature sensor, said temperature sensor produces a temperature signal based on the temperature of said processor; and

a clock module, said clock module produces the clock signal having two or more different frequencies, the frequency of the clock signal varies depending on the temperature and the activity of said processor, and

11

wherein said processor processes instructions in accordance with the clock signal supplied from said clock module.

7. A computer as recited in 1,

wherein said activity detector determines whether said processor is in a low power state or a normal power state, and

wherein said fan controller causes the speed of said fan to be substantially decreased when said activity detector determines that said processor is in the low power state as compared to the speed of said fan when said processor is in the normal state.

8. A computer as recited in claim 7, wherein said fan controller uses pulse width modulation to control the speed of said fan.

9. A computer as recited in 7, wherein the low power state is a sleep state.

10. A computer as recited in 9, wherein when said fan controller causes the speed of said fan to be substantially decreased, said fan is stopped.

11. A method for controlling speed of a fan that cools a microprocessor, said method comprising the operations of: monitoring activity of the microprocessor; producing a control signal based on the activity of the microprocessor; and controlling the speed of the fan in accordance with the control signal.

12. A method as recited in claim 11,

wherein said monitoring the activity of the microprocessor determines whether the microprocessor is in a sleep state, and

wherein said controlling of the speed of the fan operates to stop the fan when the microprocessor is determined to be in the sleep state.

13. A method as recited in claim 11,

wherein said monitoring the activity of the microprocessor identifies whether the microprocessor is in a low power state or an active state, and

wherein said controlling of the speed of the fan operates to reduce power consumption of the fan while the microprocessor is in the low power state.

14. A method as recited in claim 13, wherein said controlling of the speed of the fan is performed with pulse width modulation.

15. A method as recited in claim 13,

wherein said method further comprises the operation of monitoring temperature of the microprocessor,

wherein said producing of the control signal operates to produce the control signal based on the activity of the microprocessor and the temperature of the microprocessor, and

wherein said controlling of the speed of the fan is performed in accordance with the control signal.

16. A method as recited in claim 13, wherein the low power state is a sleep state.

17. A method for controlling speed of a fan that cools a microprocessor, said method comprising the operations of: monitoring temperature of the microprocessor; producing a control signal based on the temperature of the microprocessor; and controlling the speed of the fan in accordance with the control signal.

18. A method as recited in claim 17, wherein the fan and the microprocessor are parts of a computer.

12

19. A method as recited in claim 17, wherein the speed of the fan is controlled by the control signal such that the speed is dependent on the extent to which the temperature of the microprocessor exceeds a predetermined threshold temperature.

20. A method as recited in claim 17, wherein said controlling of the speed of the fan is performed with pulse width modulation.

21. A computer system, comprising:

a processor module, said processor module processes instructions in accordance with a clock signal, and said processor module supports a normal clock mode and a plurality of reduced power modes; and

a temperature sensor thermally coupled to said processor module, said temperature sensor produces a temperature signal based on the temperature of said processor module,

wherein the temperature signal from said temperature sensor is used to regulate the temperature of said processor module by altering the frequency of the clock signal, and

wherein overheating of said processor module is averted by reducing the frequency of the clock signal to a value associated with one of the reduced power modes.

22. A computer system as recited in claim 21, wherein said temperature sensor is internal to said processor module.

23. A computer system, comprising:

a processor module, said processor module processes instructions in accordance with a clock signal; an activity detector, said activity detector monitors activity of said processor module; and

a temperature sensor thermally coupled to said processor module, said temperature sensor produces a temperature signal based on the temperature of said processor module,

wherein the temperature signal from said temperature sensor is used to regulate the temperature of said processor module, and

wherein the frequency of the clock signal utilized by said processor module is controlled based on the temperature and the activity of said processor module.

24. A computer system, comprising:

a processor module, said processor module processes instructions in accordance with a clock signal;

an activity detector, said activity detector monitors activity of said processor module;

a temperature sensor thermally coupled to said processor module, said temperature sensor produces a temperature signal based on the temperature of said processor module; and

a clock unit operatively connected or internal to said processor module, said clock unit produces the clock signal for the processor module, the clock signal having a frequency that varies in accordance with both the activity and the temperature of the processor module,

wherein the temperature signal from said temperature sensor is used to regulate the temperature of said processor module.

25. A computer system, comprising:

a processor module, said processor module processes instructions in accordance with a clock signal;

an activity detector, said activity detector monitors activity of said processor module;

a temperature sensor thermally coupled to said processor module, said temperature sensor produces a temperature signal based on the temperature of said processor module; and

13

a clock mode selector operatively connected or internal to said processor module, said clock mode selector includes a plurality of clock modes that provide different frequencies for the clock signal utilized by said processor module, the particular mode being selected is dependent upon both the activity and the temperature of the processor module, 5

wherein the temperature signal from said temperature sensor is used to regulate the temperature of said processor module. 10

26. A thermal management method for a computer system having a microprocessor and a fan, the microprocessor performing operations at a rate determined by a clocking frequency, said thermal management method comprising the acts of: 15

- monitoring the temperature of the microprocessor;
- comparing the temperature of the microprocessor to first and second temperature thresholds, the second temperature threshold being greater than the first temperature threshold; 20
- reducing the clocking frequency when the temperature of the microprocessor is greater than the first temperature threshold; and
- activating the fan subsequent to said reducing of the clock frequency when the temperature of the microprocessor exceeds the second temperature threshold. 25

27. A method as recited in claim **26**, wherein the fan is activated only after the reduction in the clocking frequency does not operate to control thermal conditions of the microprocessor. 30

28. A method as recited in claim **26**, wherein said reducing the clocking frequency reduces the clocking frequency in predetermined amounts, and wherein said reducing the clock frequency further reduces the clocking frequency when a prior reduction in the clocking frequency is not able to prevent the temperature of the microprocessor from continuing to increase. 35

29. A method as recited in claim **26**, wherein the fan is operable at a plurality of speeds, and 40

- wherein said activating of the fan operates to determine a speed for the fan based on the temperature of the microprocessor.

30. A method as recited in claim **26**, wherein said method further comprises: 45

- determining whether said microprocessor enters a reduced power mode; and
- deactivating the fan when said determining operates to determine that said microprocessor has entered the reduced power mode. 50

31. A method as recited in claim **30**, wherein the reduced power mode is a sleep mode.

32. A computer system, comprising: 55

- a microprocessor, said microprocessor operating to perform operations in accordance with a clocking frequency;
- a fan;
- a temperature sensor thermally coupled to said microprocessor, said temperature sensor provides a temperature indication corresponding to the temperature of said microprocessor; and 60
- a thermal manager operatively connected to said microprocessor and said fan, said thermal manager being configured to receive the temperature indication from said temperature sensor, and said thermal manager compares the temperature indication to first and second temperature thresholds, causes the clocking frequency 65

14

for said microprocessor to be reduced to provide thermal management when the temperature indication indicates that the temperature of said microprocessor exceeds the first temperature threshold, and activates said fan when the temperature indication indicates that the temperature of said microprocessor exceeds the second temperature threshold, the second temperature threshold being greater than the first temperature threshold.

33. A computer system as recited in claim **32**, wherein said fan is operable in a plurality of different speeds, wherein when the temperature indication indicates that the temperature of said microprocessor does not exceed the second temperature threshold, said fan is not activated, and 15

- wherein when the temperature indication indicates that the temperature of said microprocessor does exceed the second temperature threshold, said fan is activated and the speed of said fan is dependent upon the extent that the temperature of said microprocessor exceeds the second temperature threshold.

34. A computer system as recited in claim **32**, wherein said temperature sensor is integrated into said microprocessor. 20

35. A computer system as recited in claim **32**, wherein said fan is used only after the reduction in the clocking frequency for said microprocessor does not operate to sufficiently limit the temperature of said microprocessor.

36. A computer system as recited in claim **32**, wherein said thermal controller minimizes the use of said fan so as to minimize power consumption. 25

37. A computer system as recited in claim **32**, wherein said fan is operable in a plurality of different speeds, and 30

- wherein when the temperature indication indicates that the temperature of said microprocessor does not exceed the second temperature threshold, said fan is not activated.

38. A computer system as recited in claim **32**, wherein said thermal manager deactivates the fan when said microprocessor enters a reduced power mode. 35

39. A computer system as recited in claim **32**, wherein said thermal manager deactivates the fan when said microprocessor enters a sleep mode. 40

40. A computer system as recited in claim **32**, wherein said computer system further comprises: 45

- an activity detector operatively connected to said microprocessor, said activity detector determines an activity level of said microprocessor, and
- wherein the speed of said fan is controlled based on the temperature of said microprocessor and the activity level. 50

41. A computer system as recited in claim **40**, wherein said thermal manager is operatively connected to said activity detector, and 55

- wherein when said activity detector detects that the activity level is low, said thermal manager causes the clocking frequency to be substantially reduced such that said fan need not be activated.

42. A computer system as recited in claim **41**, wherein said temperature sensor is internal to said microprocessor.

43. A computer system as recited in claim **32**, wherein said thermal controller manages the temperature of said microprocessor to avert its overheating in an energy efficient manner by avoiding the use of said fan at a first stage and instead improving thermal conditions by sacrificing 60

15

some performance of said microprocessor by lowering the clocking frequency.

44. A computer system as recited in claim **43**, wherein in a second stage said fan is also used to improve the thermal conditions when the lowering of the clocking frequency in the first stage is unable to stabilize the thermal conditions. 5

45. A computer system as recited in claim **44**, wherein in the second stage a plurality of respectively greater speeds for said fan can be used to attempt to stabilize the thermal conditions.

16

46. A computer system as recited in claim **44**, wherein in the first stage a plurality of respectively lower clocking frequencies can be used to attempt to stabilize the thermal conditions.

47. A computer system as recited in claim **46**, wherein in the second stage a plurality of respectively greater speeds for said fan can be used to attempt to stabilize the thermal conditions.

* * * * *

UNITED STATES PATENT AND TRADEMARK OFFICE
CERTIFICATE OF CORRECTION

PATENT NO. : 5,974,557
DATED : October 26, 1999
INVENTOR(S) : C. Douglass Thomas and Alan E. Thomas

Page 1 of 2

It is certified that error appears in the above-identified patent and that said Letters Patent is hereby corrected as shown below:

Title page.

Item [56], **References Cited**, U.S. PATENT DOCUMENTS, "5,721,938" should be -- 5,721,937 --.

Column 1.

Line 24, after "control", insert -- is --;
Line 45, "it" should be -- if --;
Line 60, "make" should be -- made --; and
Line 67, "keyboard" should be -- a keyboard --.

Column 2.

Line 41, "maximizes" should be -- maximize --;
Line 46, "principals" should be -- principles --.

Column 5.

Line 38, begin new paragraph at "FIG. 5"; and
Line 57, after "1", insert -- . --.

Column 6.

Line 49, "IN2. The first" should be -- based on first and second --.

Column 7.

Line 19, begin new paragraph at "Many"; and
Line 52, remove new paragraph after "invention."

Column 8.

Line 25, "pulse" should be -- pulses --; and
Line 60, "signal trigger" should be -- signals trigger --.

Column 9.

Line 2, "TABLE I" should be -- TABLE II --;
Line 22, after "that", insert -- a --;
Line 23, "addition" should be -- additional --;
Line 47, "follow" should be -- following --; and
Line 56, "by" should be -- be --.

UNITED STATES PATENT AND TRADEMARK OFFICE
CERTIFICATE OF CORRECTION

PATENT NO. : 5,974,557
DATED : October 26, 1999
INVENTOR(S) : C. Douglass Thomas and Alan E. Thomas

Page 2 of 2

It is certified that error appears in the above-identified patent and that said Letters Patent is hereby corrected as shown below:

Column 11,

Lines 4 and 16, after "in", insert -- claim --; and

Line 18, after "in", insert -- claim --.

Signed and Sealed this

Ninth Day of September, 2003

A handwritten signature in black ink, appearing to read "James E. Rogan", written over a horizontal line.

JAMES E. ROGAN
Director of the United States Patent and Trademark Office