



US006487668B2

(12) **United States Patent**
Thomas et al.

(10) **Patent No.:** US **6,487,668 B2**
(45) **Date of Patent:** *Nov. 26, 2002

(54) **THERMAL AND POWER MANAGEMENT TO COMPUTER SYSTEMS**

(76) Inventors: **C. Douglass Thomas**, 1193 Capri Dr., Campbell, CA (US) 95008; **Alan E. Thomas**, 424 Atlantic Ave., Ocean City, NJ (US) 08226

(*) Notice: Subject to any disclaimer, the term of this patent is extended or adjusted under 35 U.S.C. 154(b) by 0 days.

This patent is subject to a terminal disclaimer.

(21) Appl. No.: **09/782,680**

(22) Filed: **Feb. 12, 2001**

(65) **Prior Publication Data**

US 2001/0047494 A1 Nov. 29, 2001

Related U.S. Application Data

(63) Continuation of application No. 09/351,051, filed on Jul. 10, 1999, now Pat. No. 6,216,235, which is a continuation of application No. 08/914,299, filed on Aug. 18, 1997, now Pat. No. 5,974,557, which is a continuation of application No. 08/262,754, filed on Jun. 20, 1994, now Pat. No. 5,752,011.

(51) **Int. Cl.**⁷ **G06F 1/32**; G06F 1/08

(52) **U.S. Cl.** **713/322**; 713/501

(58) **Field of Search** 713/501; 715/320, 715/322, 500, 501

(56) **References Cited**

U.S. PATENT DOCUMENTS

3,453,601 A	7/1969	Bogert et al.
3,941,989 A	3/1976	McLaughlin et al.
4,279,020 A	7/1981	Christian et al.
4,293,927 A	10/1981	Hoshii
4,381,552 A	4/1983	Nocilini et al.
4,409,665 A	10/1983	Tubbs
4,448,543 A	* 5/1984	Vail
4,670,837 A	6/1987	Sheets

4,672,228 A	6/1987	Swoboda
4,686,386 A	8/1987	Tadao
4,689,659 A	8/1987	Watanabe
4,698,748 A	10/1987	Juzswik et al.
4,722,669 A	2/1988	Kundert
4,734,871 A	3/1988	Tsunoda et al.
4,756,473 A	7/1988	Takemae et al.

(List continued on next page.)

FOREIGN PATENT DOCUMENTS

EP	0 157 507	10/1985
EP	0 214 297 A1	3/1987
EP	0364222	4/1990
EP	0368144	* 5/1990
EP	0381021	8/1990
EP	0 419 908 A2	4/1991
EP	0 426 410 B1	5/1991
EP	0 456 012 B1	11/1991
EP	0474963	3/1992
EP	0496536	7/1992
EP	0540287	5/1993

(List continued on next page.)

OTHER PUBLICATIONS

“Cooling Control,” IBM Technical Disclosure Bulletin, vol. 18, No. 6, pp. 1705–1706, Nov. 1975.

“Computerized Control of Chilled Water System,” IBM Technical Disclosure Bulletin, vol. 20, No. 8, pp. 2981–2984, Jan. 1978.

“Variable Air Cooling for Computer And/Or Electronic Equipment,” IBM Technical Disclosure Bulletin, vol. 32, No. 10A, pp. 196–198, Mar. 1990.

Advanced Power Management (APM), BIOS Interface Specification, Revision 1.1, Sep. 1993.

Primary Examiner—Thomas M. Heckler

(57) **ABSTRACT**

Improved approaches to providing thermal and power management for a computing device are disclosed. These approaches facilitate intelligent control of a processor's clock frequency and/or a fan's speed so as to provide thermal and/or power management for the computing device.

52 Claims, 8 Drawing Sheets

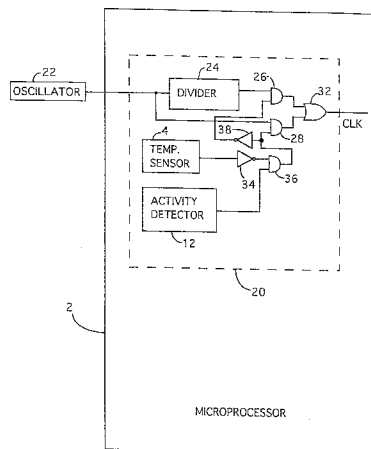

U.S. PATENT DOCUMENTS

4,812,733 A	3/1989	Tobey	
4,851,987 A	7/1989	Day	
4,893,271 A	1/1990	Davis et al.	
4,924,112 A	5/1990	Anderson et al.	
4,970,497 A	11/1990	Broadwater et al.	
4,980,836 A	12/1990	Carter et al.	
5,021,679 A	6/1991	Fairbanks et al.	
5,025,387 A	6/1991	Frane	
5,036,493 A	7/1991	Nielsen	
5,058,389 A	10/1991	Yasuda et al.	
5,115,225 A	5/1992	Dao et al.	
5,121,291 A	6/1992	Cope et al.	
5,125,088 A	6/1992	Culley	
5,132,632 A	7/1992	Russell et al.	
5,134,703 A	7/1992	Bumbarger	
5,142,684 A	8/1992	Perry et al.	
5,167,024 A	11/1992	Smith et al.	
5,189,314 A	2/1993	Georgiou et al.	
5,201,059 A	4/1993	Nguyen	
5,218,704 A	6/1993	Watts, Jr. et al.	
5,222,239 A	6/1993	Rosch	
5,230,055 A	7/1993	Katz et al.	
5,230,074 A	7/1993	Canova, Jr. et al.	
5,239,652 A	8/1993	Siebert et al.	
5,241,680 A	8/1993	Cole et al.	
5,249,741 A	10/1993	Bistline et al.	
5,254,928 A	10/1993	Young et al.	
5,287,244 A	2/1994	Hileman et al.	
5,287,292 A *	2/1994	Kenny et al.	
5,291,607 A	3/1994	Ristic et al.	
5,349,688 A	9/1994	Nguyen	
5,349,823 A *	9/1994	Solomon	
5,355,501 A	10/1994	Gross et al.	
5,359,234 A	10/1994	Atriss et al.	
5,369,771 A	11/1994	Gettel	
5,375,230 A	12/1994	Fujimori et al.	
5,381,043 A	1/1995	Kohiyama et al.	
5,388,265 A	2/1995	Volk	
5,392,437 A	2/1995	Matter et al.	
5,396,635 A	3/1995	Fung	
5,416,726 A	5/1995	Garcia-Duarte et al.	
5,418,751 A	5/1995	Kaiser	
5,422,806 A	6/1995	Chen et al.	
5,422,832 A	6/1995	Moyal	
5,426,755 A	6/1995	Yokouchi et al.	
5,428,790 A	6/1995	Harper et al.	
5,430,881 A	7/1995	Ikeda	
5,457,766 A	10/1995	Ko	
5,469,320 A	11/1995	Walker et al.	
5,469,561 A *	11/1995	Takeda	
5,473,767 A	12/1995	Kardach et al.	
5,475,847 A	12/1995	Ikeda	
5,483,102 A *	1/1996	Neal et al. 713/501 X	
5,483,656 A	1/1996	Oprescu et al.	
5,485,127 A	1/1996	Bertoluzzi et al.	
5,498,971 A	3/1996	Turnbull et al.	
5,500,509 A	3/1996	Vogt	
5,502,838 A	3/1996	Kikinis	
5,504,907 A	4/1996	Stewart et al.	
5,504,908 A	4/1996	Ikeda	
5,504,924 A	4/1996	Ohashi et al.	
5,511,203 A	4/1996	Wisor et al.	
5,526,289 A	6/1996	Dinh et al.	
5,535,401 A	7/1996	Rawson, III et al.	
5,546,568 A	8/1996	Bland et al.	
5,546,591 A	8/1996	Wurzburg et al.	
5,557,550 A	9/1996	Vigil et al.	
5,557,551 A	9/1996	Craft	
5,560,001 A	9/1996	Kardach et al.	
5,560,002 A	9/1996	Kardach et al.	
5,560,020 A	9/1996	Nakatani et al.	
5,561,792 A	10/1996	Ganapathy	
5,574,667 A	11/1996	Dinh et al.	
5,579,524 A	11/1996	Kikinis	
5,586,332 A	12/1996	Jain et al.	
5,590,061 A	12/1996	Hollowell, II et al.	
5,622,789 A	4/1997	Young	
5,623,594 A	4/1997	Swamy	
5,625,826 A	4/1997	Atkinson	
5,630,148 A	5/1997	Norris	
5,632,037 A	5/1997	Maher et al.	
5,664,201 A	9/1997	Ikedea	
5,664,205 A	9/1997	O'Brien et al.	
5,687,079 A	11/1997	Bauer et al.	
5,721,837 A	2/1998	Kikinis et al.	
5,721,937 A *	2/1998	Kurihara et al. 713/323	
5,721,938 A *	2/1998	Kurihara et al.	
5,809,336 A	9/1998	Moore et al.	
5,838,578 A *	11/1998	Pippin 716/4	

FOREIGN PATENT DOCUMENTS

EP	0 566 395 A1	10/1993
EP	0 683 558 A1	11/1995
GB	2235797 *	3/1991
JP	58-099821 A2	6/1983
JP	58-128524 A2	8/1983
JP	60-150137 A2	8/1985
JP	63-100522 A2	5/1988
JP	2-054797 A2	2/1990
JP	2-083720 A2	3/1990
JP	0363567	4/1990
JP	2-299009 A2	12/1990
JP	3-116210 A2	5/1991
JP	5-011897 A2	1/1993
JP	5108193 *	4/1993
JP	5189100 *	7/1993
JP	5-224773 *	9/1993
WO	WO91/00523	1/1991
WO	WO 91/00566	1/1991

* cited by examiner

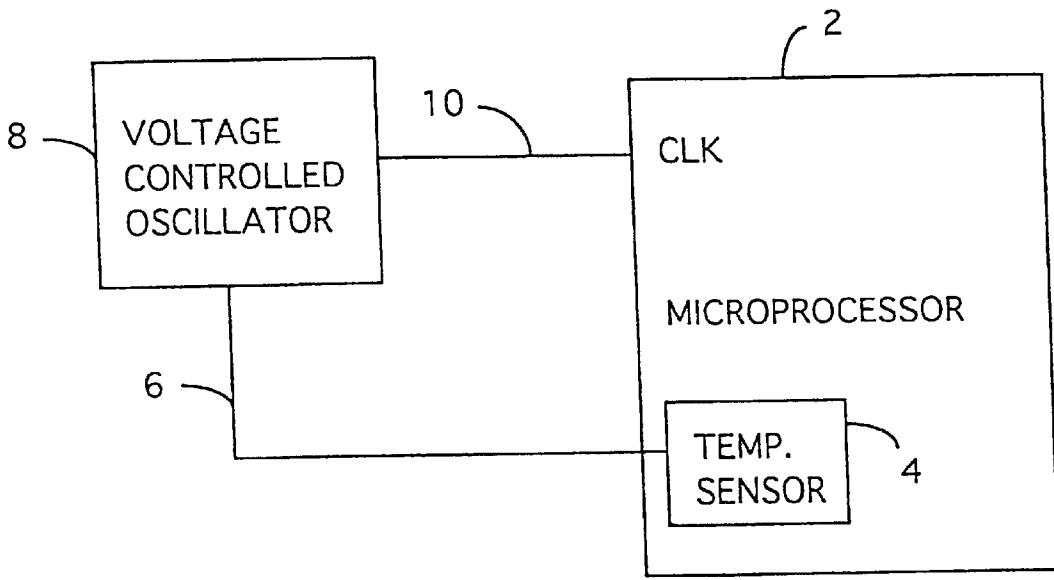

FIG. 1

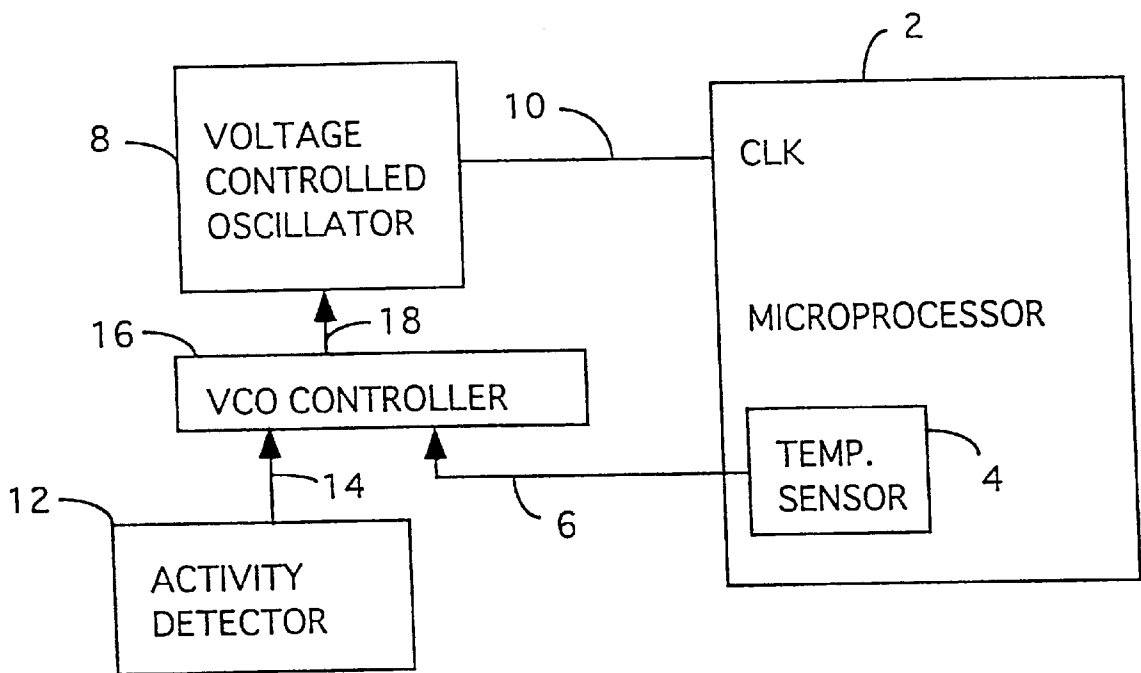

FIG. 3

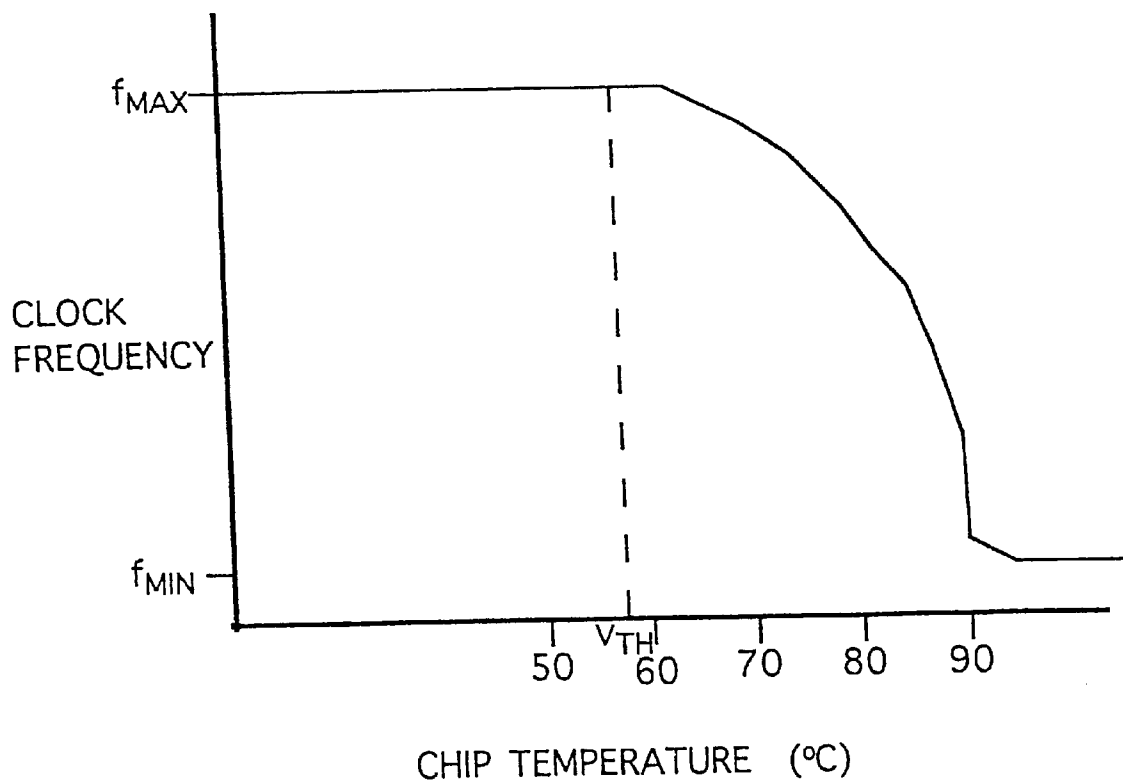

FIG. 2

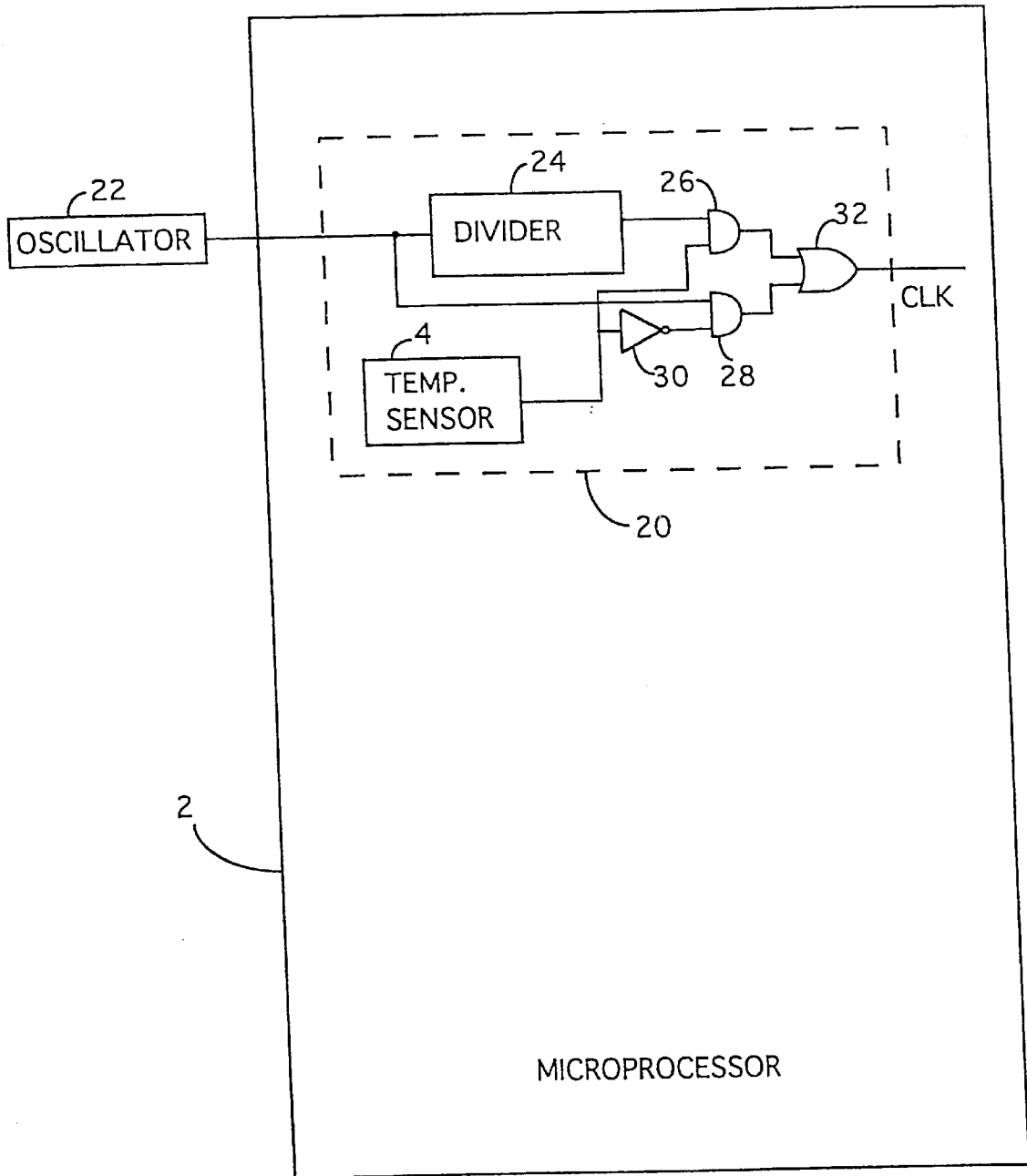

FIG. 4

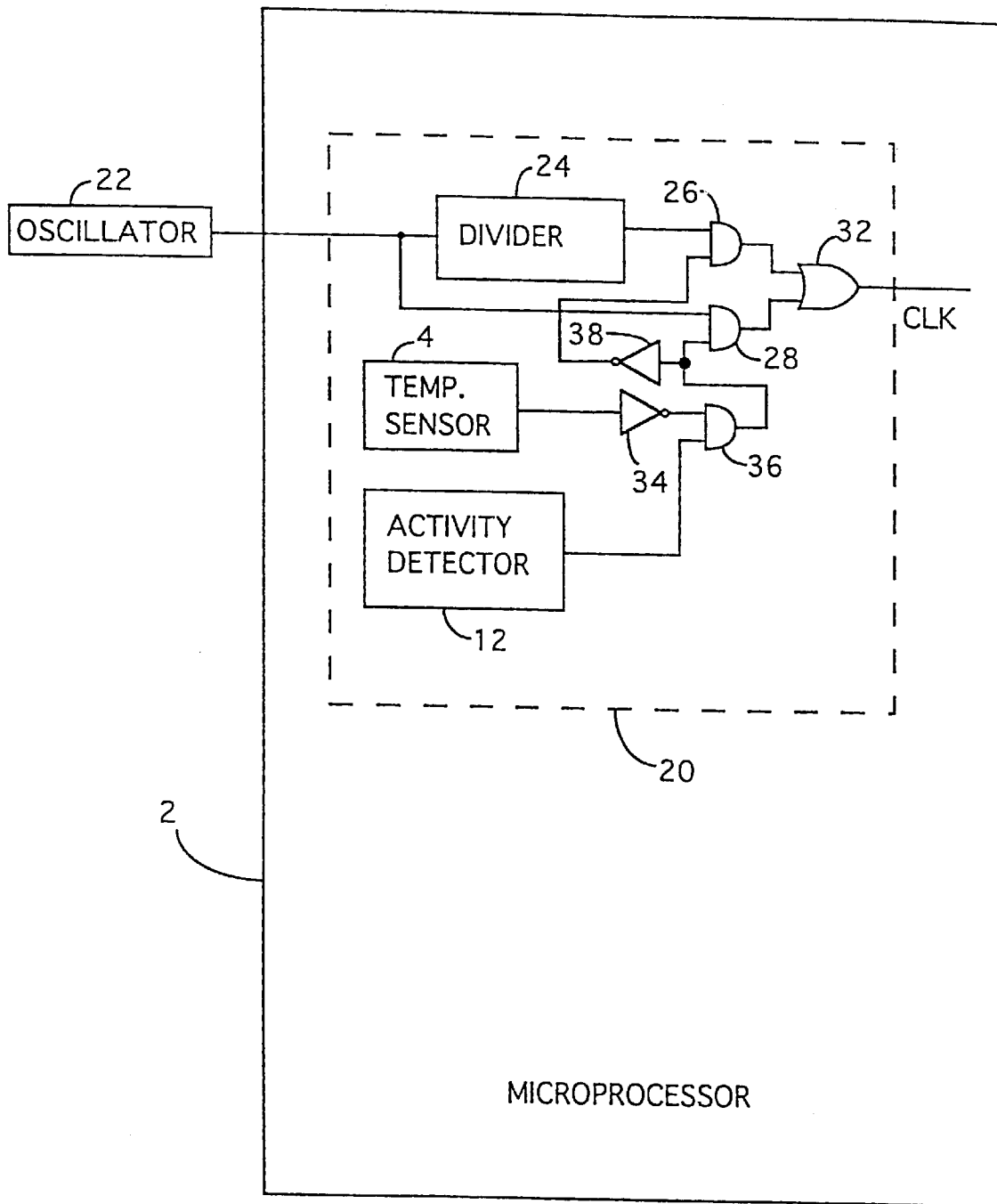

FIG. 5

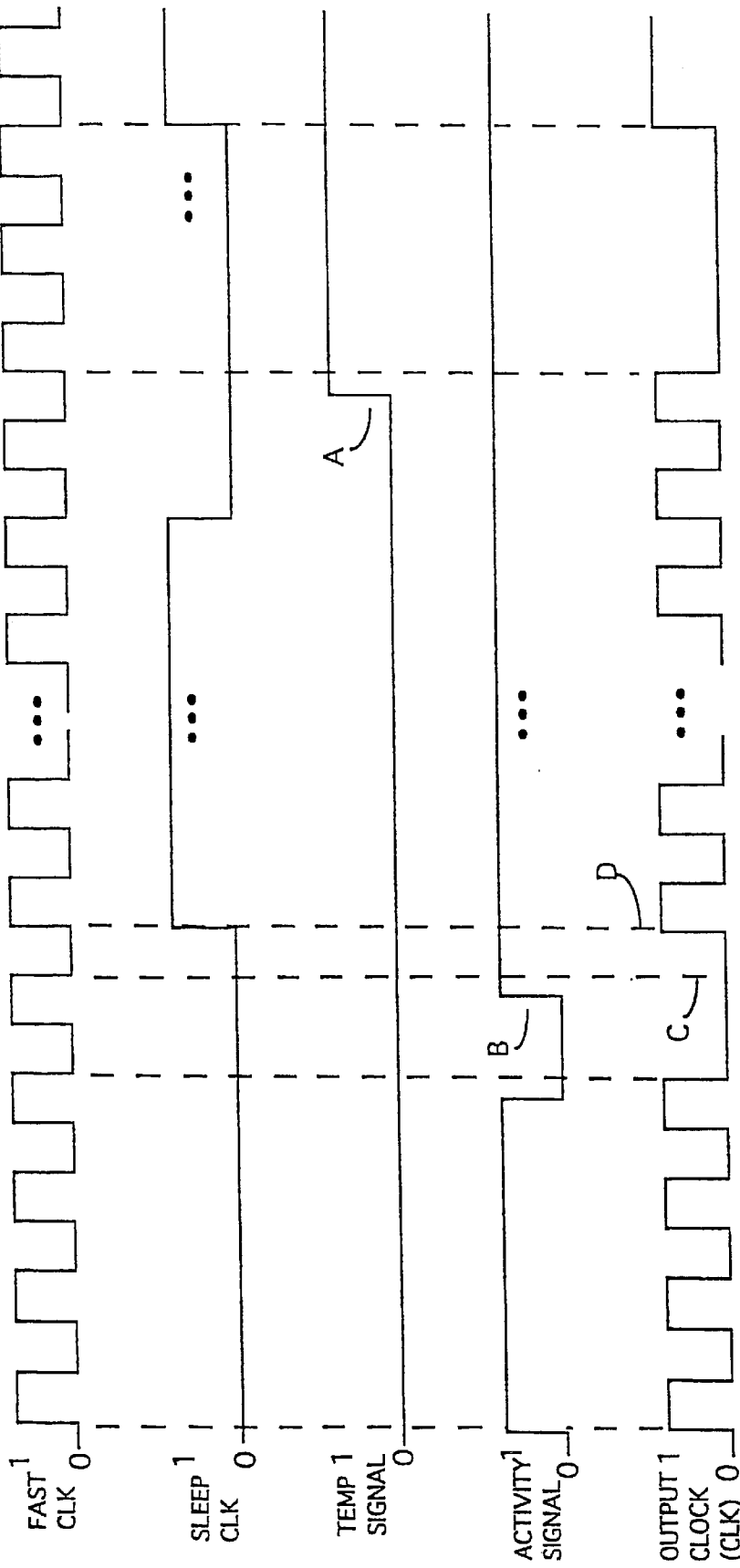

FIG. 6

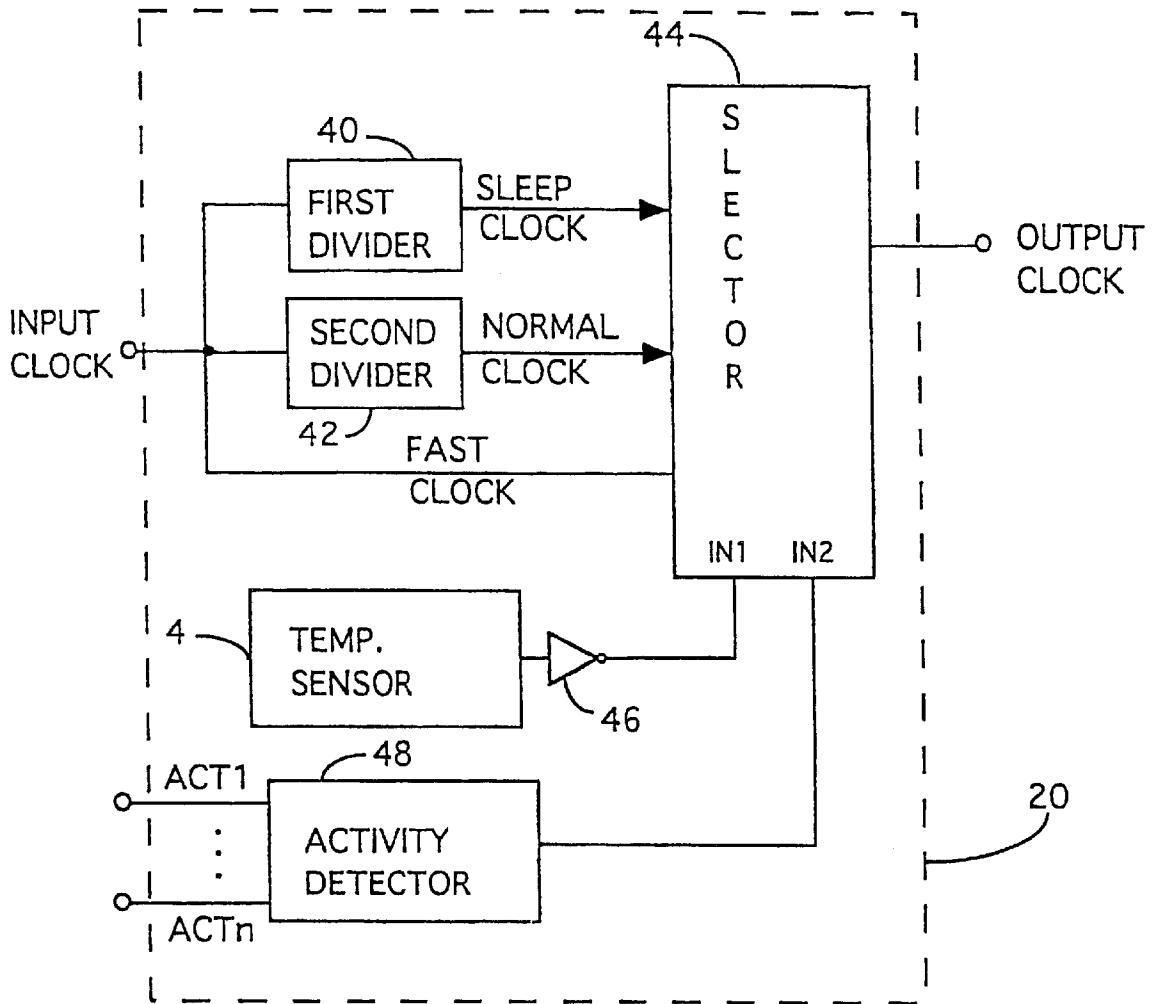

FIG. 7

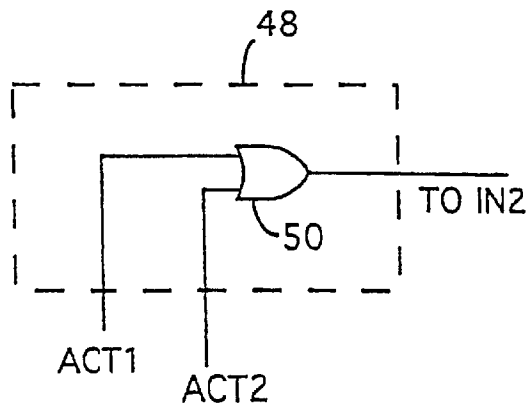

FIG. 8

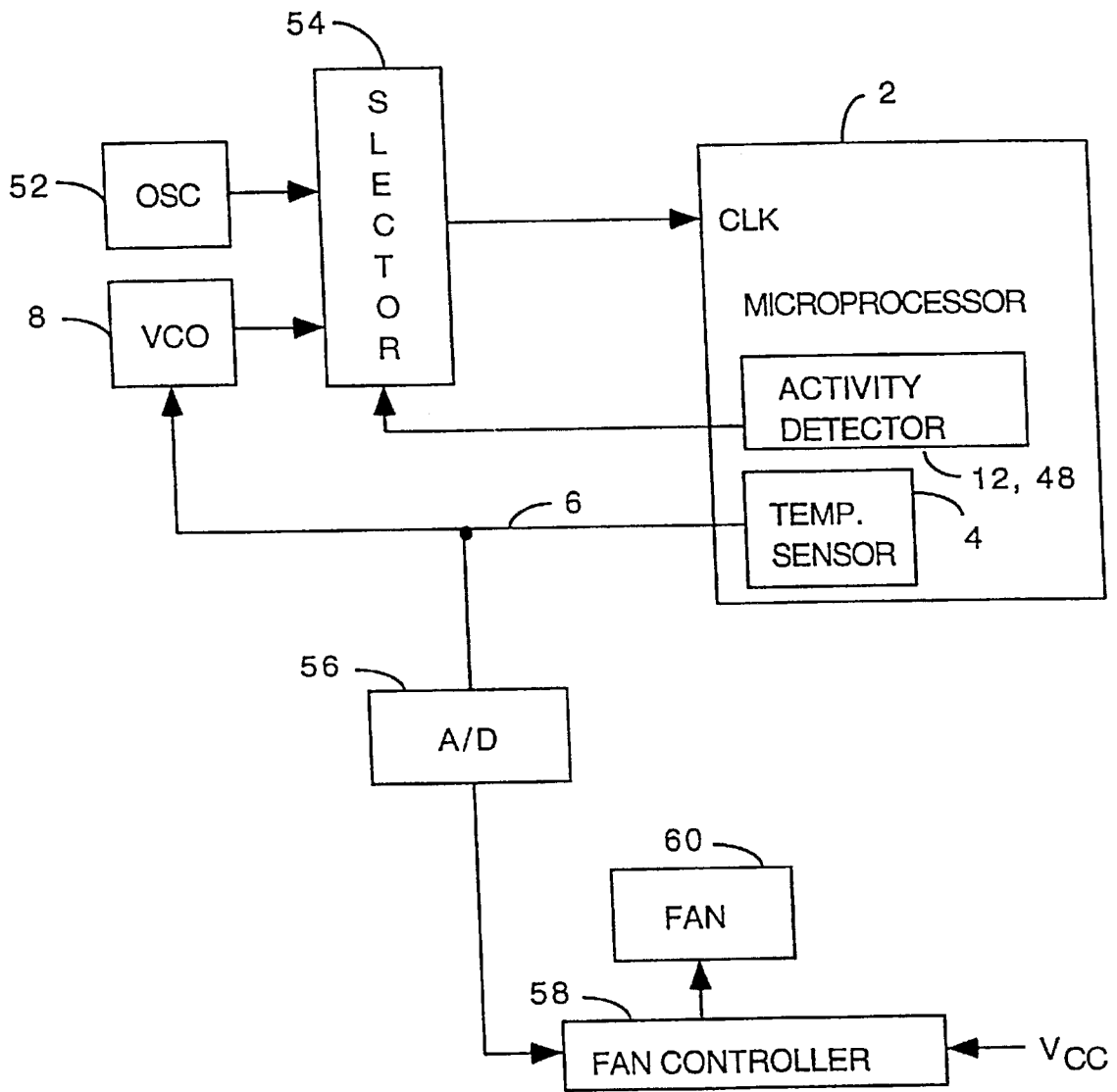

FIG. 9

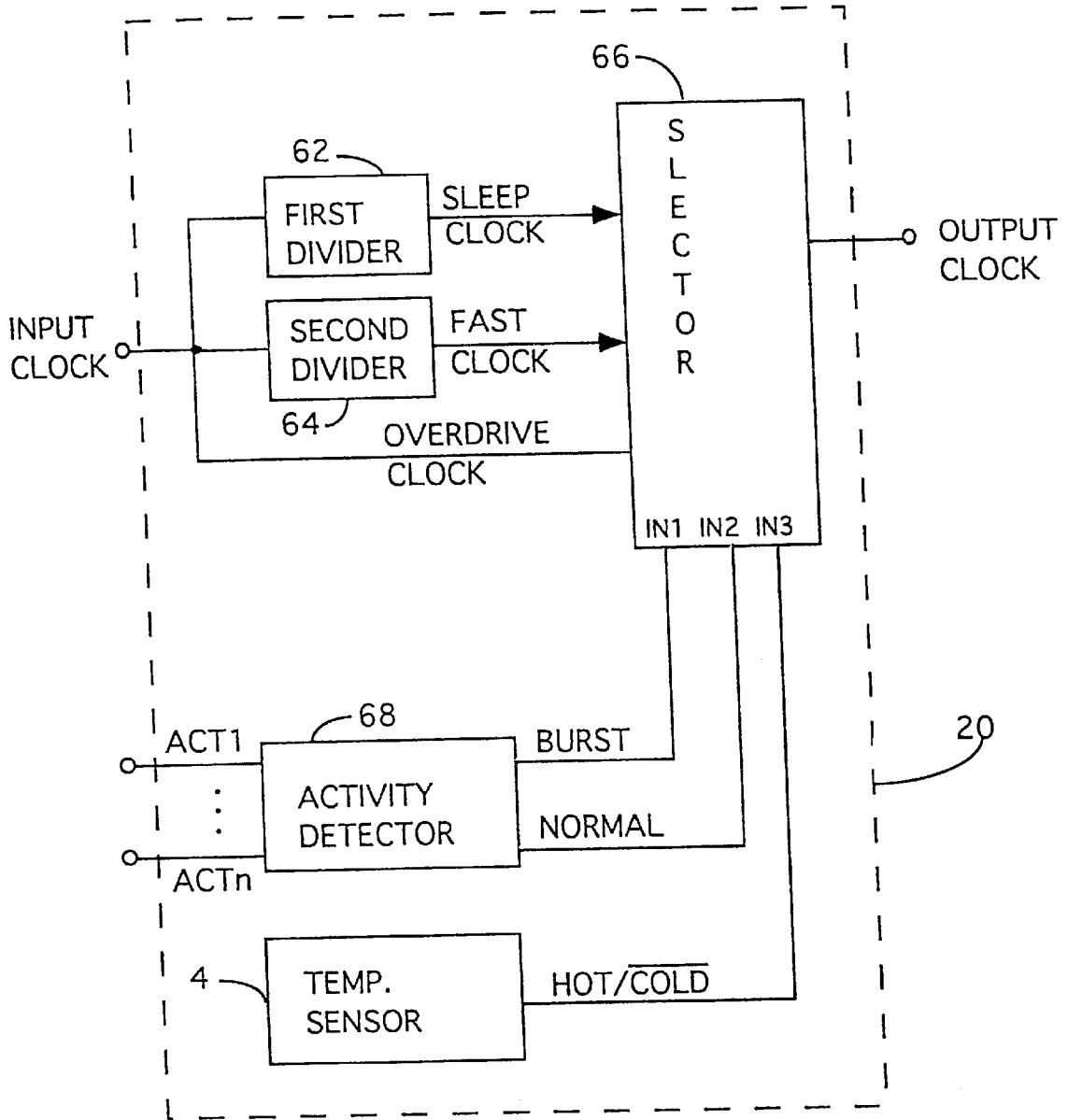

FIG. 10

THERMAL AND POWER MANAGEMENT TO COMPUTER SYSTEMS

CROSS REFERENCE TO RELATED APPLICATIONS

This application is a continuation application of prior U.S. Application No. 09/351,051 filed on Jul. 10, 1999, now U.S. Pat. No. 6,216,235, which is a continuation application of U.S. application No. 08/914,299 filed on Aug. 18, 1997, now U.S. Pat. No. 5,974,557, which is a continuation application of U.S. application No. 08/262,754 filed Jun. 20, 1994, now U.S. Pat. No. 5,752,011, the disclosure of both of which are incorporated herein by reference.

BACKGROUND OF THE INVENTION

1. Field of the Invention

The present invention relates to a computing device and, more particularly, to a method and apparatus for controlling a processor's clock frequency.

2. Description of the Related Art

It is known that if no user activity has occurred for a period of time that a portable computer can be placed in a suspend or sleep mode. It is also known to suspend or slow a computer's processor (e.g., microprocessor, CPU) when the processor is not actively processing. The following patents and patent publications are representative of the current state of the art:

(a) U.S. Pat. No. 5,201,059 discloses a sleep mode which is activated when control given to BIOS or alternatively by incorporating some statistical analysis of the frequency of BIOS calls. In this patent, the sleep mode either stops the clock or slows it to 4 MHz.

(b) U.S. Pat. No. 5,167,024 discloses a power management system for a laptop computer. The power management system operates to disconnect power sources and/or clock signals to various peripheral devices to conserve battery power. The slow mode is entered into when no activity has been detected for a predetermined period of time.

(c) U.S. Pat. No. 5,218,704 discloses a technique for power conservation based on real-time sampling of CPU activity. The activity is sampled during interrupts and when it determines that the CPU may rest, a sleep clock is supplied to the CPU. The detection of an interrupt restores the clock to the fast rate prior to processing the interrupt.

(d) U.S. Pat. No. 5,239,652 discloses a technique for power consumption which disconnects the CPU from the power supply when control logic determines the CPU is not actively processing. Thereafter, the CPU is periodically powered-up to perform housekeeping chores as well as to determine if normal processing should be resumed.

(e) European patent publication EP-0474963 discloses a sleep mode controller which lowers the CPU clock speed when no input/output operation (when keyboard control routine of BIOS executed no input key data in key buffer, or when CPU is idle and no input key data in the key buffer) is performed. The system uses a clock generator circuit which produces the low clock (4 MHz), the high clock (32 MHz) and a slightly slower high clock (16 MHz). A keyboard controller is used to determine which of the high clocks is used, with selection being made by the computer user. The sleep mode controller is disabled if the AC adapter is connected.

(f) U.S. Pat. No. 5,230,055 discloses a portable computer wherein the computer is made inoperable when ambient temperature or humidity become too high. Here, ambient temperature and humidity are periodically monitored.

(g) European patent publication EP-0381021 discloses a power saving system for a personal computer. The system operates to allow or stop power to be supplied to an oscillator based on control data set to a control register via keyboard or software.

(h) U.S. Pat. No. 5,021,679 discloses a power system for a portable computer wherein the supply voltage is varied depending on the current being supplied to the computer by the power system. Further, a variable-frequency clock is provided which varies its frequency based on the supply voltage being produced.

External clocks have been used to provide a computer system with faster clocks. Here, the faster external clock is substituted for the internal clock of the computer system. U.S. Pat. No. 5,134,703 is illustrative of an external clock unit which supplies a faster clock to a computer without requiring any hardware changes within the computer.

The problem with all the prior solutions to energy conservation is that the processors can still overheat. In particular, during prolonged processing or activity by a computer's processor, the processor will not enter its sleep mode (if any) and as a result the processor will become hot and require extensive means to cool the processor to prevent overheating and eventual failure of the processor. Overheating and failure of the processor can also occur when the computer is used in particularly hot environmental temperatures, the computer's cooling fan fails, or when cooling of the processor is otherwise inadequate.

Another problem is that with portable computers, manufacturers have to either use a lower clock frequency (lower than would be used in a comparable desk top computer) for processing or provide a fan for cooling. A lower clock frequency is not satisfactory as users want maximum processing power just as they get with a desk top computer. Requiring a portable computer to use a fan for cooling is also unsatisfactory because it consumes battery energy.

Thus, there is a need for a solution to the above problems which enables a computing device to maximize its processing speed while, at the same time, preventing overheating.

SUMMARY OF THE INVENTION

Broadly speaking, the invention relates to novel techniques for providing thermal and power management for a computing device. These techniques facilitate intelligent control of a processor's clock frequency and/or a fan's speed so as to provide thermal and/or power management for the computing device.

The invention may be implemented as an apparatus or a method. According to one embodiment, the invention monitors a processor's activity and its temperature. When there is no activity for the processor, a slowed clock frequency is used, thereby saving power and lowering the thermal heat produced by the processor. On the other hand, when there is activity for the processor, a fast clock frequency is used. However, when prolonged activity (i.e., sustained fast clock frequency) causes the processor's temperature to become dangerously high for proper operation, the clock frequency is reduced so as to maintain processing speed at a reduced speed while preventing overheating.

Other aspects and advantages of the invention will become apparent from the following detailed description, taken in conjunction with the accompanying drawings, illustrating by way of example the principals of the invention.

BRIEF DESCRIPTION OF THE DRAWINGS

The present invention will be readily understood by the following detailed description in conjunction with the

accompanying drawings, wherein like reference numerals designate like structural elements, and in which:

FIG. 1 is a block diagram of a first embodiment of the invention;

FIG. 2 is a graph of an example of the relationship of chip temperature of a microprocessor and frequency of a clock signal;

FIG. 3 is a block diagram of a second embodiment of the invention;

FIG. 4 is a block diagram of a third embodiment of the invention;

FIG. 5 is a block diagram of a fourth embodiment of the invention;

FIG. 6 is a timing diagram illustrating operation of the fourth embodiment;

FIG. 7 is a block diagram of a fifth embodiment of the invention;

FIG. 8 illustrates a schematic diagram of an embodiment of an activity detector;

FIG. 9 is a block diagram of a sixth embodiment of the invention; and

FIG. 10 is a block diagram of a seventh embodiment of the invention.

DETAILED DESCRIPTION OF THE INVENTION

The invention provides novel techniques for controlling a processor's clock frequency so as to prevent overheating. In addition to preventing overheating, the invention attempts to maximize the processing speed of the processor. The invention also operates to conserve the amount of energy consumed by the processor. Preventing the processor from overheating is important because when a processor overheats it no longer operates properly. Conservation of energy, although of general importance for all computing devices, is particularly important for portable computing devices.

The invention monitors a processor's activity and its temperature. When there is no activity for the processor, a slow clock frequency is used, thereby saving power and lowering the thermal heat produced by the processor. On the other hand, when there is activity for the processor, a fast clock frequency is used. However, when prolonged activity (i.e., sustained fast clock frequency) causes the processor's temperature to become dangerously high for proper operation, the clock frequency is reduced so as to maintain processing speed at a reduced speed while preventing overheating.

Embodiments of the invention are discussed below with reference to FIGS. 1-10. However, those skilled in the art will readily appreciate that the detailed description given herein with respect to these figures is for explanatory purposes as the invention extends beyond these limited embodiments.

FIG. 1 is a block diagram of a first embodiment of the invention. In this embodiment, a microprocessor 2 has a temperature sensor 4 which is integral with the microprocessor 2. The temperature sensor 4 is either integrated within the Very Large Scale Integration (VLSI) design of the microprocessor 2 or placed in contact with the housing or package thereof. In either case, the temperature sensor 4 is thermally coupled with the microprocessor 2. Because the temperature sensor 4 is integral or thermally coupled with the microprocessor 2, the temperature sensor 4 is very responsive to the temperature changes of the microprocessor

2. The temperature sensor 4 produces a temperature signal 6. Temperature sensing circuitry is well known and therefore not further described.

The temperature signal 6 is supplied to a voltage-controlled oscillator (VCO) 8. The VCO 8 produces a clock signal 10 which is supplied to a clock input of the microprocessor 2. The VCO 8 operates to produce different frequencies for the clock signal 10 depending on the value of the temperature signal. In this embodiment, the temperature signal 6 is preferably an analog voltage signal and the VCO 8 produces the clock signal 10 based on the value of the analog voltage signal. For example, the temperature signal could be a voltage ranging from zero to five volts. In response to the temperature signal 6, the VCO 8 could produce the clock signal with frequencies ranging from 100 MHz to 1 MHz. The frequency range is a design choice selected in accordance with the specific microprocessor being utilized. VCO's are well known and therefore are not further described.

FIG. 2 is a graph of an example of the relationship of chip temperature of the microprocessor 2 and clock frequency of the clock signal 10. The clock frequency varies between a maximum frequency (f_{MAX}) and a minimum frequency (f_{MIN}) for given microprocessor. The minimum frequency (f_{MIN}) may be zero if the clock signal 10 is not responsible for refreshing dynamic memory; otherwise, it cannot fall below some minimum frequency. Notice that as the chip temperature increases beyond some threshold temperature (VTH) (e.g., 120 degrees F), the frequency of the clock signal 10 will gradually decrease. By decreasing the clock frequency in relation to the chip temperature, processing speed can be maximized for a given temperature without risking processor overheating. As the chip temperature become "hot", the clock frequency is reduced so as to reduce the thermal heat generated by the microprocessor 2. The profile of the curve for the clock frequency shown in FIG. 2 is illustrative as other curves may be used. For example, the frequency of the clock signal 10 could be controlled so that the chip temperature is maintained in a more limited temperature range. In any case, the profiles of the curves decrease the clock frequency as the temperature increases.

FIG. 3 is a block diagram of a second embodiment of the invention. In this embodiment, the microprocessor 2, temperature sensor 4, the temperature signal 6, the VCO 8, and the clock signal 10 are similar to those utilized in the first embodiment. However, this embodiment further includes an activity detector 12, an activity signal 14, a VCO controller 16, and a control signal 18. The activity detector 12 monitors the microprocessor 2 and/or some related peripheral device (e.g., interrupt controller, keyboard buffer, input/output ports, instruction cache, current instruction, program counter) to determine when the microprocessor 2 is actively processing or when processing is needed. In this case, the detector 12 notifies the VCO controller 16 that processing is needed with the activity signal 14. On the other hand, when no activity exists, the detector 12 notifies the VCO controller 16 that no processing is needed with the activity signal 14. The activity signal is preferably a digital signal having at least one bit. Activity detection is described in more detail in U.S. Pat. Nos. 5,201,059; 5,167,024; 5,218,704; 5,239,652; and European patent publication EP-0474963, which are hereby incorporated by reference.

The VCO controller 16 receives the activity signal 14 and the temperature signal 6. In response to these signals, the VCO controller 16 produces the control signal 18 which controls the VCO 8. The control signal 18 may be analog or digital depending on the design of the VCO 8. The basic

operation of the VCO controller 16 is to cause the VCO 8 to produce the clock signal 10 for the microprocessor 2 in an intelligent manner so as to conserve energy and prevent overheating. Namely, if the activity detector 12 indicates that no processing is needed at a given point in time, then regardless of the temperature detected by the temperature sensor 4, the VCO controller 16 will cause the VCO 8 to produce a sleep (or slow) clock. The sleep clock has a frequency near the minimum frequency (f_{MIN}). On the other hand, if the detector 12 indicates that processing is needed at this point in time, then the VCO controller 16 will cause the VCO 8 to produce a fast clock. The fast clock is the temperature-regulated maximum frequency such as discussed in FIGS. 1 and 2.

The second embodiment is particularly advantageous for portable computing devices because it conserves battery life by using a sleep clock when no processing is needed. However, even in the case of prolonged processing, the embodiment prevents overheating.

FIG. 4 is a block diagram of a third embodiment of the invention. In this embodiment, the microprocessor 2 includes a clock regulation unit 20 which controls the frequency of the clock used by the microprocessor 2 based on chip temperature of the microprocessor 2. Preferably, the clock regulation unit 20 is integrated with circuitry of the microprocessor 2. Alternatively, the clock regulation unit 20 can be separate from the circuitry of the microprocessor 2 but nevertheless coupled thereto.

The clock regulation unit 20 receives an input clock from an oscillator 22 and produces an output clock which is used by the microprocessor 2. The clock regulation unit 20 includes a temperature sensor 4, a divider 24, a first AND gate 26, a second AND gate 28, an inverter 30 and an OR gate 32. The temperature sensor 4 is as previously described. The divider 24 divides the input clock (fast clock) from the oscillator 22 to produce a sleep (or slow) clock. For example, if the oscillator 22 is a 100 MHz fixed-frequency oscillator and the divider 24 divides by 100, then the sleep clock would be 1 MHz.

In this embodiment, the temperature sensor 4 produces a digital output. It is assumed that the digital output is normally "0" but when the microprocessor 2 becomes "hot", the digital output becomes "1". The digital output of the temperature sensor 4 together with the logic gates 26-32 operate to select either the fast clock or the sleep clock as the output clock which is used by the microprocessor 2. In particular, when the microprocessor 2 is not "hot", AND gate 26 is inactivated and AND gate 28 is activated by inverter 30. Hence, the output clock is the fast clock via AND gate 28 and OR gate 32. On the other hand, when the microprocessor 2 is "hot", AND gate 26 is activated and AND gate 28 is inactivated. Accordingly, in this case, the output clock is the sleep (or slow) clock via AND gate 26 and OR gate 32.

FIG. 5 is a block diagram of a fourth embodiment of the invention. In this embodiment, the microprocessor 2 includes a clock regulation unit 20 which controls the frequency of the clock used by the microprocessor 2 based on chip temperature of the microprocessor 2 and processing activity. The clock regulation unit 20 is preferably integrated with circuitry of the microprocessor 2.

As with the third embodiment, the clock regulation unit 20 for the fourth embodiment receives the input clock from the oscillator 22 and produces the output clock which is used by the microprocessor 2. The clock regulation unit 20 includes the temperature sensor 4, the divider 24, the first AND gate 26, the second AND gate 28, and the OR gate 32

as described above with reference to FIG. 4. The divider 24 divides the input clock (fast clock) from the oscillator 22 to produce a sleep clock. The temperature sensor 4 produces a digital output. Although the digital output from the temperature sensor 4 is normally "0", when the microprocessor 2 becomes "hot", the digital output becomes "1". The detector 12 produces an activity signal as described in the second embodiment. Here, the activity signal is a digital signal which is "high" or "1" when activity is present and "low" or "0" when no activity is present.

The digital output of the temperature sensor 4 together with the activity signal from the detector 12 and the logic gates 26, 28, 32, 34, 36 and 38 operate to select either the fast clock or the sleep clock. In particular, when the microprocessor 2 is not "hot" and activity is present, the AND gate 36 is activated by the inverter 34 and the activity signal. The output of AND gate 36 then activates AND gate 28 and inverter 38 inactivates AND gate 26. Hence, the output clock is the fast clock via AND gate 28 and OR gate 32. On the other hand, when the microprocessor 2 is "hot", the AND gate 36 is inactivated by the inverter 34 regardless of the activity signal. The output of AND gate 36 inactivates AND gate 28, and inverter 38 activates the AND gate 26. In this case, the output clock is the sleep clock via AND gate 26 and OR gate 32.

FIG. 6 is a timing diagram illustrating operation of the fourth embodiment. The output clock (CLK) is a mixture of the fast clock produced by the oscillator 22 and the sleep clock produced by the divider 24. The temperature signal is the digital output of the temperature sensor 4. The temperature signal is "0" while the chip temperature is not "hot". However, when the chip temperature becomes "hot", the temperature signal becomes "1", as shown at point A. The activity signal is "1" when activity is present for processing by the microprocessor 2; otherwise, the activity signal is "0" to indicate no activity is present for processing. As shown in FIG. 6, the output clock follows the fast clock only when the temperature signal is "0" and the activity signal is "1"; otherwise, the output clock follows the sleep clock. Note that the transitions for the output clock from fast clock to sleep clock and from sleep clock to fast clock are shown as being synchronized with the low or "0" portion of the fast clock. For example, at point B the output clock would produce a partial pulse (from the fast clock) if not synchronized. Hence, it is probably preferred that switching occur only when the fast clock is "low," or when both the fast and sleep clocks are "low" as shown at point C. Note that at point C, the output clock transitions from the sleep clock to the fast clock but because the transition is synchronized with the "low" portion of the fast clock, the first pulse does not occur until point D. Such synchronization can be insured by the addition of known circuitry.

FIG. 7 is a block diagram of a fifth embodiment of the invention. Although only the clock regulation unit 20 is illustrated in FIG. 7, the fifth embodiment interacts with an oscillator 22 and a microprocessor 2 as did the third and fourth embodiments. In this embodiment, the clock regulation unit 20 includes a first divider 40 which divides the input clock (fast clock) to produce a sleep clock, and a second divider 42 which divides the input clock to produce a normal clock. The three clocks (sleep, normal and fast) are then supplied to a selector 44. The selector 44 outputs one of the three clocks as the output clock for the microprocessor 2 based on first and second select inputs IN1 and IN2. The first select input IN1 is generated by inverting the digital output from the temperature sensor 4 using an inverter 46. The second select input IN2 is generated by an activity

detector 48 which functions similarly to the detector 12 in previous embodiments.

The activity detector 48 receives a plurality of activity inputs ACT1, . . . , ACTn. For example, the activity inputs notify the activity detector 48 whether or not activity exists. Each of the activity inputs may, for example, indicate an interrupt, keyboard activity, modem line activity, I/O port activity, or processor activity. As an example, FIG. 8 illustrates a schematic diagram of an embodiment of the activity detector 48. The activity detector 48 includes a OR gate 50 which outputs a "1" when either the activity input ACT1 or the activity input ACT2 is "1". If neither the activity signals ACT1 and ACT2 are "1", then the OR gate 50 outputs a "1", thereby indicating the presence of activity.

The following Table I illustrates the selection of one of the three clocks by the selector 44 based on the first select input IN1 and the second select input IN2.

TABLE I

IN1	IN2	CLK Mode
0	0	Sleep
0	1	Fast
1	0	Sleep
1	1	Normal

Note that when no activity is detected by the activity detector 48, then the sleep clock is output. However, when activity is detected, then the normal clock is output if the chip temperature is "hot" and the fast clock is output if the chip temperature is not "hot". Like previous embodiments, this embodiment prevents overheating and conserves energy. Many alternatives can be made to the third, fourth and fifth embodiments discussed above. For example, additional clocks with different clock frequencies could be provided and selected for different temperature ranges to provide a more gradual decrease in frequency. However, if a microprocessor has sufficient thermal heat dissipation, then even the embodiment with only two different clock frequencies (fast and sleep) may provide reasonable processing speeds even when the microprocessor is getting hot because the switching between the clocks would be quite fast as the response of the temperature sensor 4 is very rapid because it is integrated with the microprocessor. Further, although FIGS. 4, 5, and 7 illustrate the temperature sensor 4 as resident within the clock regulation unit 20, the temperature sensor 20 need only be electrically coupled thereto and closely thermally coupled to the microprocessor 2.

FIG. 9 is a block diagram of a sixth embodiment of the invention. In this embodiment, the clock (CLK) received by a microprocessor 2 is either a sleep clock produced by an oscillator 52 or a temperature-regulated fast clock produced by a VCO 8 in accordance with a temperature signal 6 (analog) from a temperature sensor 4. Clock selection is achieved by a selector 54 based on an activity signal 14 provided by an activity detector 12, 48. The VCO 8, the temperature sensor 4 and the activity detector 12, 48 were discussed above with respect to previous embodiments. If activity is present, the temperature-regulated fast clock is supplied to the microprocessor 2. On the other hand, if no activity is detected, then the sleep clock is supplied to the microprocessor 2. The temperature regulation of the fast clock is achieved by the analog temperature signal as discussed above with regard to FIGS. 1 and 2.

Additionally, FIG. 9 illustrates an additional feature of the invention. Namely, FIG. 9 includes an analog-to-digital converter 56, a fan controller 58 and a cooling fan 60. Many

conventional computing systems include a fan for circulating air through a computer's cabinet or add-on fans that provide air-flow on or near a microprocessor. Such add-on fans can be activated in accordance with ambient temperature. In contrast, the invention allows more accurate temperature monitoring of the microprocessor 2 because the temperature sensor 4 is integrated with the microprocessor 2. In addition, the invention facilitates more sophisticated energy conservation which is particularly important for portable computing devices. The temperature signal 6 is converted to digital form by the A/D converter 56 and then supplied to the fan controller 58. The fan controller 58 performs a pulse-width modulation operation on a supply voltage (Vcc) so as to control the speed of the fan 60. Pulse-width modulation of the supply voltage allows the speed of the fan to be controlled without wasting energy. Thus, this embodiment further includes a temperature-activated, variable-speed fan.

In the case of a desk-top computing device, it is desirable to activate the fan 60 just prior to the temperature where the fast clock would be regulated downward because of high chip temperature. On the other hand, in the case of a portable computing device, it is desirable to attempt to limit the use of the fan 60 as much as possible by allowing the fast clock to be gradually reduced with increasing temperature before utilizing the fan 60. For example, if the maximum frequency of the fast clock is 100 MHz, the fan 60 could be activated in the desk-top case before the frequency would be regulated (e.g., attempts to maintain 100 MHz). This would eliminate or delay the reduction in the frequency of the fast clock. In the portable case, the fan 60 could be activated after the frequency of the fast clock is already decreased to 25 MHz. The fan 60 would then only be used when necessary to insure reasonable processing power and even then at the lowest effective speed, thereby saving battery energy to the extent possible.

Although not shown but described with reference to FIG. 6, depending on the particular design, synchronization of the switching of the frequency may be needed to prevent partial pulse in the clock signal. Such synchronization is easily implemented using well-known circuitry. Likewise, if the computing device requires a consistent clock period during certain events (e.g., analog-to-digital conversion), then hysteresis or other circuitry can be added to restrict the ability of the frequency of the clock to be changed during certain times.

Prior embodiments operate to decrease the clock frequency of the clock signals supplied to a microprocessor to prevent overheating and to conserve energy. FIG. 10 is a block diagram of a seventh embodiment of the invention. This embodiment operates to provide a burst processing mode for use under certain conditions. During certain types of processing activity, a clock control unit 20 causes an overdrive clock to be supplied to a microprocessor 2. Because the overdrive clock is used only in short bursts, the frequency of the overdrive clock can and preferably exceeds the frequency which sustained processing would permit without rapidly overheating.

In this embodiment, the clock control unit 20 includes a first divider 62 which divides the input clock to produce a sleep clock, and a second divider which divides the input clock to produce a fast clock. Because the input clock serves as the overdrive clock, the input clock has a clock frequency that is faster than that necessary for sufficient performance and responsiveness in most cases. The clock control unit 20 also includes a selector 66, an activity detector 68, and a temperature sensor 4. The selector 66 operates to select one

of the sleep, fast or overdrive clocks based on select inputs (IN1, IN2, IN3) it receives from the activity detector 68 and the temperature sensor 4. More particularly, the activity detector 68 receives activity signals ACT1, . . . , ACTn which cause the activity detector 68 to generate a burst activity signal and a normal activity signal. Certain of the activity signals ACT trigger the burst activity signal and other activity signal trigger the normal activity signal. The temperature sensor 4 is integral with the microprocessor 2 and produces a digital temperature signal which indicates whether or not the microprocessor 2 is "hot".

The following Table II illustrates the selection of one of the three clocks by the selector 66 based on the first select input IN1, the second select input IN2, and the third select input.

TABLE I

IN1	IN2	IN3	CLK Mode
0	0	0	Sleep
0	0	1	Sleep
0	1	0	Fast
0	1	1	Sleep
1	0	0	Overdrive
1	0	1	Fast/Sleep
1	1	0	Overdrive
1	1	1	Fast/Sleep

Note that when no activity (either burst or normal) is detected by the activity detector 68, then the sleep clock is output. However, when burst activity is detected, then the overdrive clock is output if the chip temperature is not "hot" and either the fast clock or the sleep clock is output if the chip temperature is "hot". The determination of which of the fast or sleep clocks to output in this situation is a design choice depending on the ability of the computing system to dissipate heat. In fact, it may be preferred to make the selection more sophisticated in this case so that selector can make the decision using addition temperature information such as signals indicating particular temperature ranges or rate at which temperature is rising. When only normal activity is detected, then the fast clock is output if the chip temperature is not "hot" and the sleep clock is output if the chip temperature is "hot". As a modification, the second divider 64 could be replaced with a VCO thereby using a temperature-regulated fast clock.

Like previous embodiments, this embodiment prevents overheating and conserves energy. The advantage of this embodiment is that processing will appear more uniform or regular to a user.

There are certain times during normal execution of a program, the computer is caused to execute operations which are beyond or unrequested by the program being executed. Such unrequested operations include interrupt processing, and data transfer to cache memory following a cache miss. Using the overdrive clock in these types of situations is advantageous because such will substantially lessen any delay induced by these unrequested operations. A computer user then perceives that the computer's responsiveness is more regular and uniform. For example, when a cache miss occurs an instruction currently being in process is not allowed to complete until the appropriate data block is loaded into the cache. The loading of the cache follow a cache miss causes the microprocessor to execute many operations for memory management that were not requested by the computer program or the user, thereby delaying the execution of the instruction. However, because the invention performs such unrequested operations at higher speeds

(overdrive clock), the impact of having to perform the extra unrequested operations is substantially lessened and hopefully invisible.

In fact, a particular computer instruction could be used to indirectly select the desired clock frequency for the instruction. This could be useful for instructions that require more intensive processing than do normal instructions. An example of intensive processing is complex floating point computations. Here, the microprocessor would indicate to the activity detector that the overdrive clock is to be used if the chip temperature is not too "hot".

Yet another embodiment would be to alter processing frequency for extremely cold situations. Namely, if the temperature sensor indicates that the chip temperature (could also use ambient temperature) is less than a predetermined minimum temperature, then the clock frequency could be set regardless of activity to its maximum value to thereby cause the generation of as much heat as possible so that the computing device could operate correctly even in extremely cold conditions. Any cooling fan of the computing device would also be shut-off using a fan controller such as shown in FIG. 9.

The many features and advantages of the present invention are apparent from the written description and thus it is intended by the appended claims to cover all such features and advantages of the invention. Further, since numerous modifications and changes will readily occur to those skilled in the art, it is not desired to limit the invention to the exact construction and operation as illustrated and described. Hence, all suitable modifications and equivalents may be resorted to as falling within the scope of the invention.

What is claimed is:

1. A computing apparatus, comprising:

- a processing unit, said processing unit executes instructions in accordance with a clock signal having a clock frequency;
- a temperature sensor that monitors temperature of said processing unit;
- an activity detector that monitors activity of said processing unit; and
- a clock control unit operatively connected to said processing unit and said temperature sensor and said activity detector, said clock control unit operates to alter the clock frequency of the clock signal in a gradual and dynamic manner based on the temperature of said processing unit as monitored by said temperature sensor and on the activity of said processing unit as monitored by said activity detector.

2. A computing apparatus as recited in claim 1, wherein said clock control unit operates to decrease the clock frequency when the temperature of said processing unit is too high.

3. A computing apparatus as recited in claim 1, wherein said computing apparatus is a microprocessor.

4. A computing apparatus as recited in claim 1, wherein said computing apparatus is a computer system.

5. A computing apparatus as recited in claim 1,

wherein said clock control unit operates to increase the clock frequency when demanded by the activity of said processing unit, and

wherein said clock control unit operates to decrease the clock frequency when the temperature of said processing unit is too high.

6. A computer, comprising:

- a processor, said processor processes instructions in accordance with a clock signal;

11

an activity detector operatively connected to said processor, said activity detector monitors activity of said processor, said activity detector determines whether said processor is in normal power mode or a reduced power mode;

a fan; and

a fan controller, said fan controller controls the speed of said fan in accordance with the activity of said processor such that the speed of said fan is less utilized when said processor is in the reduced power mode than when said processor is in the normal power mode.

7. A computer as recited in claim 6, wherein said fan controller uses pulse width modulation to control the speed of said fan.

8. A computer as recited in 6, wherein the reduced power mode includes at least a sleep state.

9. A computer as recited in claim 8, wherein when said fan controller causes said fan to stop when said processor is in the sleep state.

10. A computer as recited in claim 6, wherein said computer further comprises a temperature sensor that produces a temperature signal, and wherein said fan controller controls the speed of said fan based at least in part on the temperature signal.

11. A computer as recited in claim 10, wherein said temperature sensor produces the temperature signal based on the temperature of said processor.

12. A computer, comprising:

a processor that operates in accordance with a clock, the clock having a clock frequency;

a temperature sensor that provides a temperature indication; and

a fan; and

a thermal manager operatively connected to said microprocessor and said fan, said thermal manager being configured to receive the temperature indication from said temperature sensor, and said thermal manager activates said fan when the temperature indication indicates that primary thermal management is required, and subsequently reduces the clock frequency of the clock for said processor when the temperature indication indicates that supplemental thermal management is required even after said fan has been activated.

13. A computer as recited in claim 12, wherein when said thermal manager reduces the clock frequency of the clock for said processor such reduction is performed in a gradual manner.

14. A computer as recited in claim 12, wherein said fan is a variable-speed fan, and wherein when said thermal manager activates said fan, the speed of said fan is dependent on the temperature indication.

15. A computer as recited in claim 12, wherein said thermal manager deactivates said fan when said processor enters a reduced power mode.

16. A computer as recited in claim 12, wherein the temperature indication pertains to the temperature of said processor.

17. A computer as recited in claim 16, wherein said processor is a microprocessor.

18. A computer as recited in claim 12, wherein said fan is a variable-speed fan, wherein said computer further comprises:

an activity detector operatively connected to said processor, said activity detector determines an activity level of said processor, and

12

wherein when said thermal manager activates said fan, the speed of said fan is controlled based on the temperature of said processor and the activity level.

19. A computer as recited in claim 18, wherein said thermal manager is operatively connected to said activity detector, and wherein when said activity detector detects that the activity level is low, said thermal manager causes the clock frequency of the clock to be substantially reduced such that said fan need not be activated.

20. A computer as recited in claim 12, wherein said thermal manager manages the temperature of said processor to advert its overheating in a performance manner by using said fan for primary thermal management to improve thermal conditions without sacrificing some performance of said processor by lowering the clock frequency.

21. A computer as recited in claim 20, wherein the lowering of the clocking frequency of said processor is used for supplemental thermal management to improve the thermal conditions when use of said fan for primary thermal management is unable to stabilize the thermal conditions.

22. A computer as recited in claim 21, wherein with primary thermal management a plurality of respectively greater speeds for said fan can be used to attempt to stabilize the thermal conditions.

23. A computer as recited in claim 21, wherein with supplemental thermal management a plurality of respectively lower clock frequencies for the clock can be used to attempt to stabilize the thermal conditions.

24. A method for providing thermal management for a computer, the computer including at least a processor and a cooling fan, said method comprising:

monitoring temperature of the processor;

activating a cooling fan when the temperature of the processor indicates that primary thermal management is requires; and

subsequently reducing operational clock frequency of the processor when the temperature of the processor indicates that supplemental thermal management is required even after the cooling fan has been activated.

25. A method as recited in claim 24, wherein the speed of the cooling fan is controlled using pulse-width modulation.

26. A method as recited in claim 24, wherein when the cooling fan is initially activated, the speed of the cooling fan is increased in a gradual manner as additional primary thermal management is needed.

27. A method as recited in claim 24, wherein said activating of the cooling fan increases the speed of the cooling fan in a gradual manner to provide different levels of the primary thermal management.

28. A method as recited in claim 24, wherein said reducing of the operational clock frequency reduces the operational clock frequency by an amount dependent on the temperature of the processor.

29. A method as recited in claim 24, wherein said reducing of the operational clock frequency of the processor is performed in a gradual manner to provide different levels of the supplemental thermal management.

30. A method as recited in claim 24, wherein the operational clock frequency of the processor is altered with hysteresis.

31. A method as recited in claim 24, wherein the cooling fan is a variable-speed fan, and wherein said activating of the cooling fan causes the cooling fan to operate at a speed that is dependent on the temperature of the processor.

13

32. A method as recited in claim 31, wherein when the cooling fan is initially activated, the speed of the cooling fan is relatively slow and the speed of the cooling fan thereafter increases in a gradual manner when the temperature of the processor increases.

33. A method as recited in claim 24, wherein the cooling fan is a variable-speed fan, and

wherein the primary thermal management operates the cooling fan at successively greater speeds to provide a plurality of different levels of the primary thermal management.

34. A method as recited in claim 33, wherein the level of the primary thermal management being performed is dependent on the temperature of the processor.

35. A method as recited in claim 24, wherein the supplemental thermal management reduces the operational clock frequency by successively greater amounts to provide a plurality of different levels of the supplemental thermal management.

36. A method as recited in claim 35, wherein the level of the supplemental thermal management being performed is dependent on the temperature of the processor.

37. A method for providing thermal management for a computer, the computer including at least a processor and a cooling fan, said method comprising:

- monitoring temperature of the processor;
- monitoring activity of the processor;
- activating a cooling fan when the temperature and the activity of the processor indicate that primary thermal management is required; and

subsequently reducing operational clock frequency of the processor when the temperature and the activity of the processor indicate that supplemental thermal management is required even after the cooling fan has been activated.

38. A method as recited in claim 37, wherein when the cooling fan is initially activated, the speed of the cooling fan is increased in a gradual manner as additional primary thermal management is needed.

39. A method as recited in claim 37, wherein said activating of the cooling fan increases the speed of the cooling fan in a gradual manner to provide different levels of the primary thermal management.

40. A method as recited in claim 37, wherein said reducing of the operational clock frequency reduces the operational clock frequency by an amount dependent on the temperature and the activity of the processor.

41. A method as recited in claim 37, wherein said reducing the operational clock frequency of the processor is performed in a gradual manner to provide different levels of the supplemental thermal management.

42. A method as recited in claim 37, wherein the operational clock frequency of the processor is altered with hysteresis.

43. A method as recited in claim 37, wherein the cooling fan is a variable-speed fan, and

wherein said activating of the cooling fan causes the cooling fan to operate at a speed that is dependent on the temperature and the activity of the processor.

44. A method as recited in claim 43, wherein when the cooling fan is initially activated, the speed of the cooling fan is relatively slow and the speed of the cooling fan thereafter increases in a gradual manner when the temperature of the processor increases.

14

45. A method as recited in claim 37, wherein the cooling fan is a variable-speed fan, and

wherein the primary thermal management operates the cooling fan at successively greater speeds to provide a plurality of different levels of the primary thermal management.

46. A method as recited in claim 45, wherein the level of the primary thermal management being performed is dependent on the temperature and the activity of the processor.

47. A method as recited in claim 37, wherein the supplemental thermal management reduces the operational clock frequency by successively greater amounts to provide a plurality of different levels of the supplemental thermal management.

48. A method as recited in claim 47, wherein the level of the supplemental thermal management being performed is dependent on the temperature and the activity of the processor.

49. A method for providing thermal management for a computer, the computer including at least a processor and a cooling fan, said method comprising:

- monitoring temperature of the processor;
- comparing the temperature of the processor with at least a first temperature threshold and a second predetermined temperature, the second predetermined temperature corresponding to a greater temperature than the first predetermined temperature;
- activating a cooling fan when the temperature of the processor exceeds the first predetermined temperature; and

reducing operational clock frequency of the processor when the temperature of the processor exceeds the second predetermined temperature,

wherein the cooling fan provides primary thermal management and reduction in the operational clock frequency of the processor provides secondary thermal management.

50. A method as recited in claim 49, wherein said method further comprises:

increasing the operational clock frequency of the processor when the temperature of the processor drops substantially below the second predetermined temperature, provided that the operational clock frequency was previously reduced by said reducing, or deactivating the cooling fan when the temperature of the processor is substantially less than the first predetermined temperature, provided that the cooling fan was previously activated by said activating.

51. A method as recited in claim 49, wherein said method further comprises:

increasing the operational clock frequency of the processor when the temperature of the processor drops substantially below the second predetermined temperature, provided that the operational clock frequency was previously reduced by said reducing.

52. A method as recited in claim 51, wherein said method further comprises:

deactivating the cooling fan when the temperature of the processor is substantially less than the first predetermined temperature, provided that the cooling fan was previously activated by said activating.

UNITED STATES PATENT AND TRADEMARK OFFICE
CERTIFICATE OF CORRECTION

PATENT NO. : 6,487,668 B2
DATED : November 26, 2002
INVENTOR(S) : C. Douglass Thomas and Alan E. Thomas

Page 1 of 2

It is certified that error appears in the above-identified patent and that said Letters Patent is hereby corrected as shown below:

Title page, Item [54] and Column 1, line 1,
“**TO**” should be -- **FOR** --.

Title page,
Item [56], **References Cited**, FOREIGN PATENT DOCUMENTS, “JP 58-128524 A2”
should be -- JP 58-129524 A2 --; and “JP 0363567” should be -- EP 036567 --.

Column 1,
Line 29, after “control”, insert -- is --;
Line 51, “it” should be -- if --; and
Line 65, “make” should be -- made --.

Column 2,
Line 5, “keyboard” should be -- a keyboard --; and
Line 62, “principals” should be -- principles --.

Column 6,
Line 6, “detector” should be -- activity detector --.

Column 7,
Line 33, begin a new paragraph at “Many”.

Column 8,
Line 40, change “pulse” to -- pulses --.

Column 9,
Line 8, “signal trigger” should be -- signals trigger --;
Line 17, “TABLE I” should be -- TABLE II --;
Line 37, after “that”, insert -- a --;
Line 38, “addition” should be -- additional --; and
Line 62, “follow” should be -- following --.

UNITED STATES PATENT AND TRADEMARK OFFICE
CERTIFICATE OF CORRECTION

PATENT NO. : 6,487,668 B2
DATED : November 26, 2002
INVENTOR(S) : C. Douglass Thomas and Alan E. Thomas

Page 2 of 2

It is certified that error appears in the above-identified patent and that said Letters Patent is hereby corrected as shown below:

Column 10,

Line 4, "by" should be -- be --.

Column 14,

Line 8, "if" should be -- is --.

Line 25, "first temperature threshold" should be -- first predetermined temperature --.

Signed and Sealed this

Sixth Day of April, 2004

A handwritten signature in black ink that reads "Jon W. Dudas". The signature is written in a cursive style with a large, looped initial "J".

JON W. DUDAS
Acting Director of the United States Patent and Trademark Office

UNITED STATES PATENT AND TRADEMARK OFFICE
CERTIFICATE OF CORRECTION

PATENT NO. : 6,487,668 B2
DATED : November 26, 2002
INVENTOR(S) : Thomas et al.

Page 1 of 1

It is certified that error appears in the above-identified patent and that said Letters Patent is hereby corrected as shown below:

Title page,

Item [56], **References Cited**, U.S. PATENT DOCUMENTS, insert:

-- 5,539,681 A 07/1996 Alexander et al. --

Signed and Sealed this

Fifth Day of April, 2005

A handwritten signature in black ink on a light gray dotted background. The signature reads "Jon W. Dudas" in a cursive style.

JON W. DUDAS

Director of the United States Patent and Trademark Office

UNITED STATES PATENT AND TRADEMARK OFFICE
CERTIFICATE OF CORRECTION

PATENT NO. : 6,487,668 B2
APPLICATION NO. : 09/782680
DATED : November 26, 2002
INVENTOR(S) : Thomas et al.

Page 1 of 1

It is certified that error appears in the above-identified patent and that said Letters Patent is hereby corrected as shown below:

Column 12, line 13 (claim 20, line 3) "advert" should be --avert--.

Signed and Sealed this
Twenty-sixth Day of April, 2011

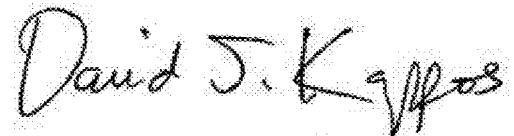
A handwritten signature in black ink that reads "David J. Kappos". The signature is written in a cursive style with a large initial "D".

David J. Kappos
Director of the United States Patent and Trademark Office

UNITED STATES PATENT AND TRADEMARK OFFICE
CERTIFICATE OF CORRECTION

PATENT NO. : 6,487,668 B2
APPLICATION NO. : 09/782680
DATED : November 26, 2002
INVENTOR(S) : C. Douglass Thomas and Alan E. Thomas

Page 1 of 1

It is certified that error appears in the above-identified patent and that said Letters Patent is hereby corrected as shown below:

IN THE CLAIMS:

Column 12, line 37 (claim 27, line 7) "requires" should be --required--.

Signed and Sealed this
Eighth Day of November, 2011

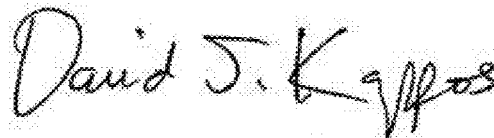
A handwritten signature in black ink that reads "David J. Kappos". The signature is written in a cursive, slightly slanted style.

David J. Kappos
Director of the United States Patent and Trademark Office